

CM Shank Series

Cutter Bits

CM42 **CMM4**

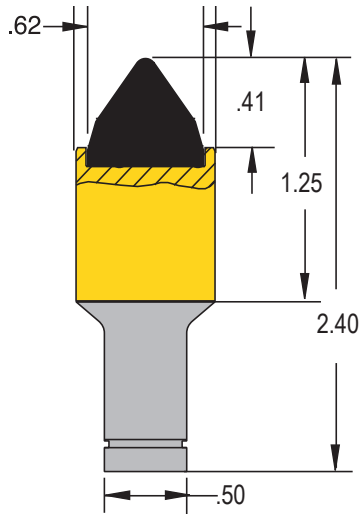

For drilling in soft to medium conditions.
Use with CMB4 Block

CM64

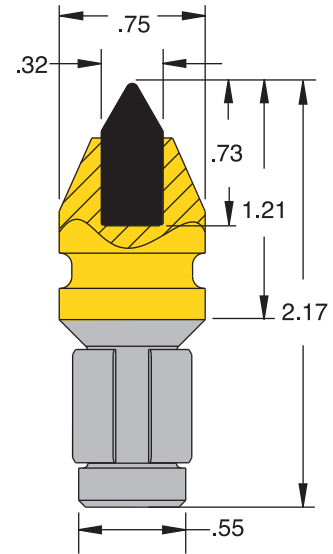

For drilling in medium to hard conditions.
Small-diameter tip and slender nose profile for
increased penetrations. LR-style retainer for easy
installation and removal.
Use with CMB6 Block

CM66 **CMM4FLR**

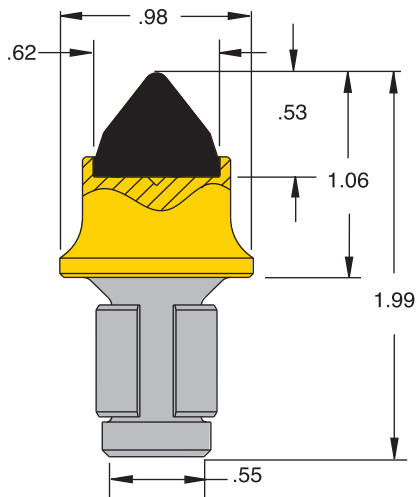

For drilling in soft to medium conditions.
Sharp tip profile for better penetration.
Use with CMB6 Block

Tool	Old Tool Name	Pieces per container	Container Weight	
			lbs.	kg.
CM42	CMM4	200	34.96	15.89
CM64		200	33.01	15.00
CM66	CMM4FLR	200	41.12	18.69

CM Series Blocks

CMB4

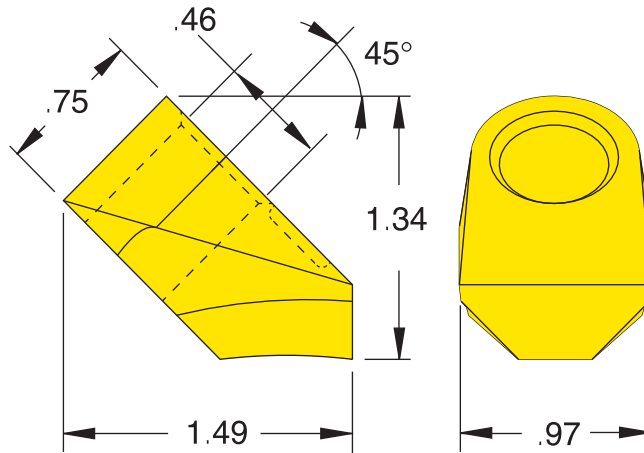

CMB6

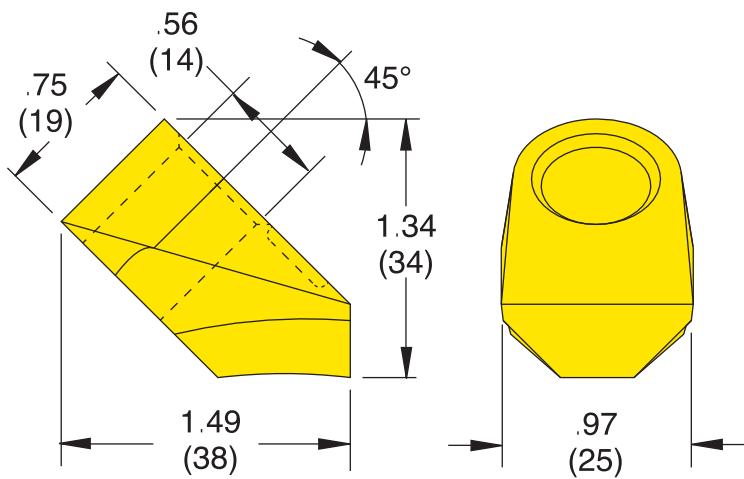

CMB6L

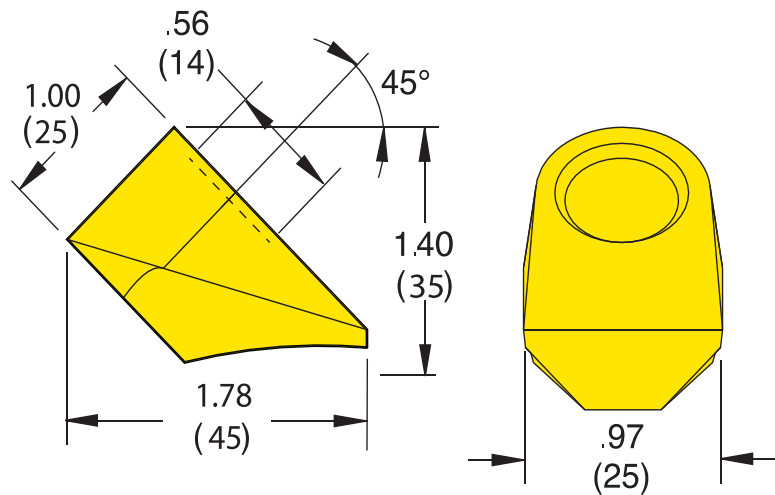

Cutter Bits

.74 Shank Series

C21

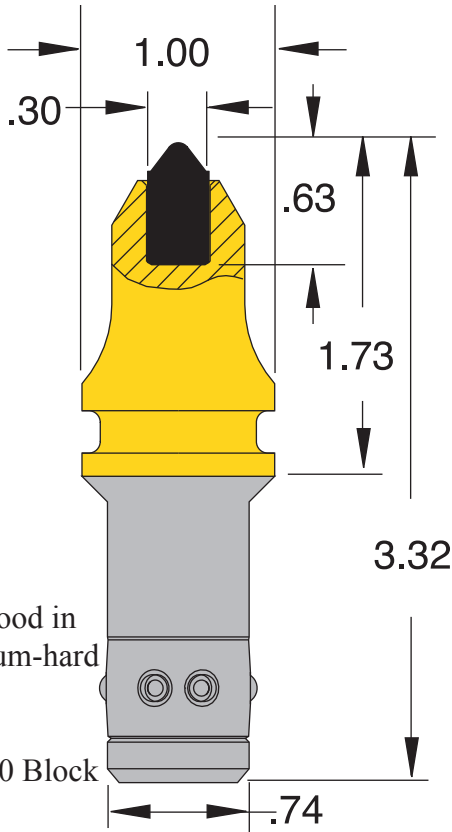

For most cutting applications. Especially good in soft to medium-hard material.

Use with C20 Block

C21HD

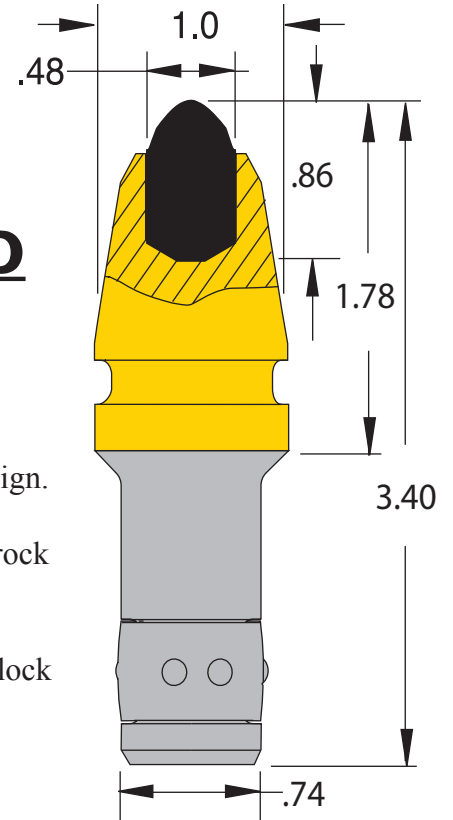

Heavy-Duty design. For augering in extremely hard rock and concrete.

Use with C20 Block

C21FHD

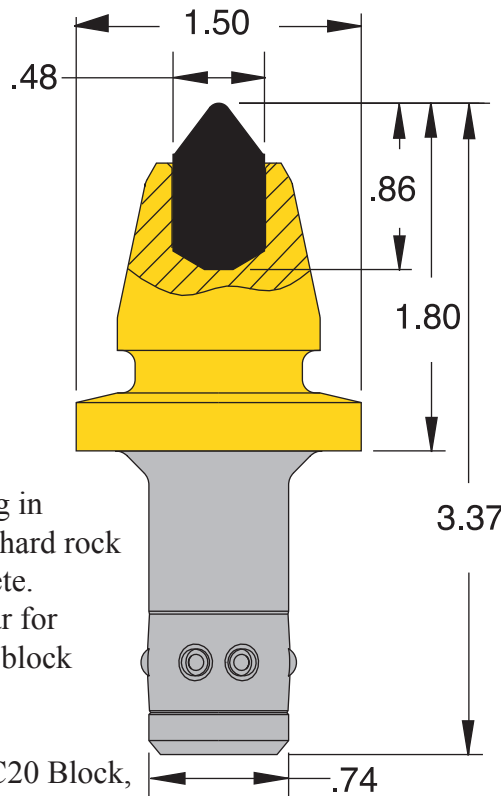

For drilling in extremely hard rock and concrete. Wide collar for maximum block protection.

Use with C20 Block,

C23

For drilling and core-barreling in soft to medium-hard rock with abrasive cutting conditions.

Use with C20 Block.

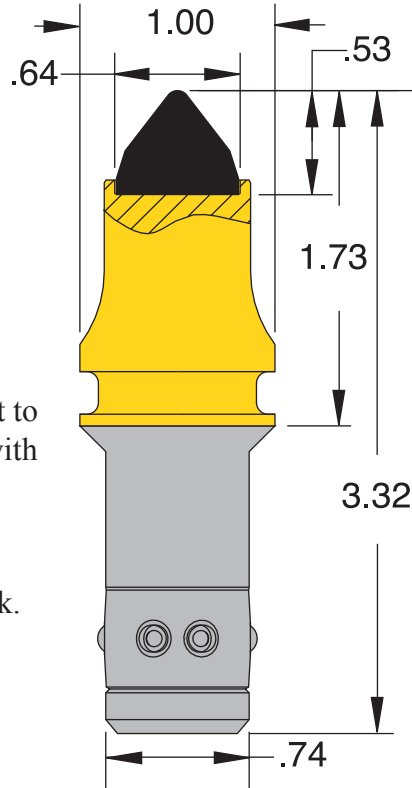

C24

For drilling soft material.
Sharp tip nose for high penetration.

Use with C20 Block.

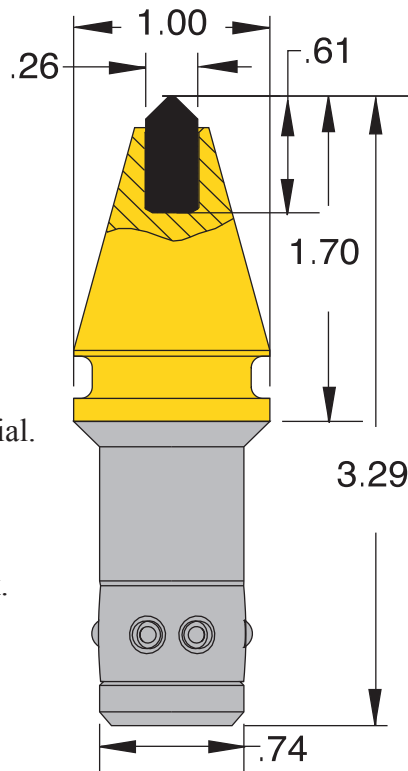

.74 Seires Blocks

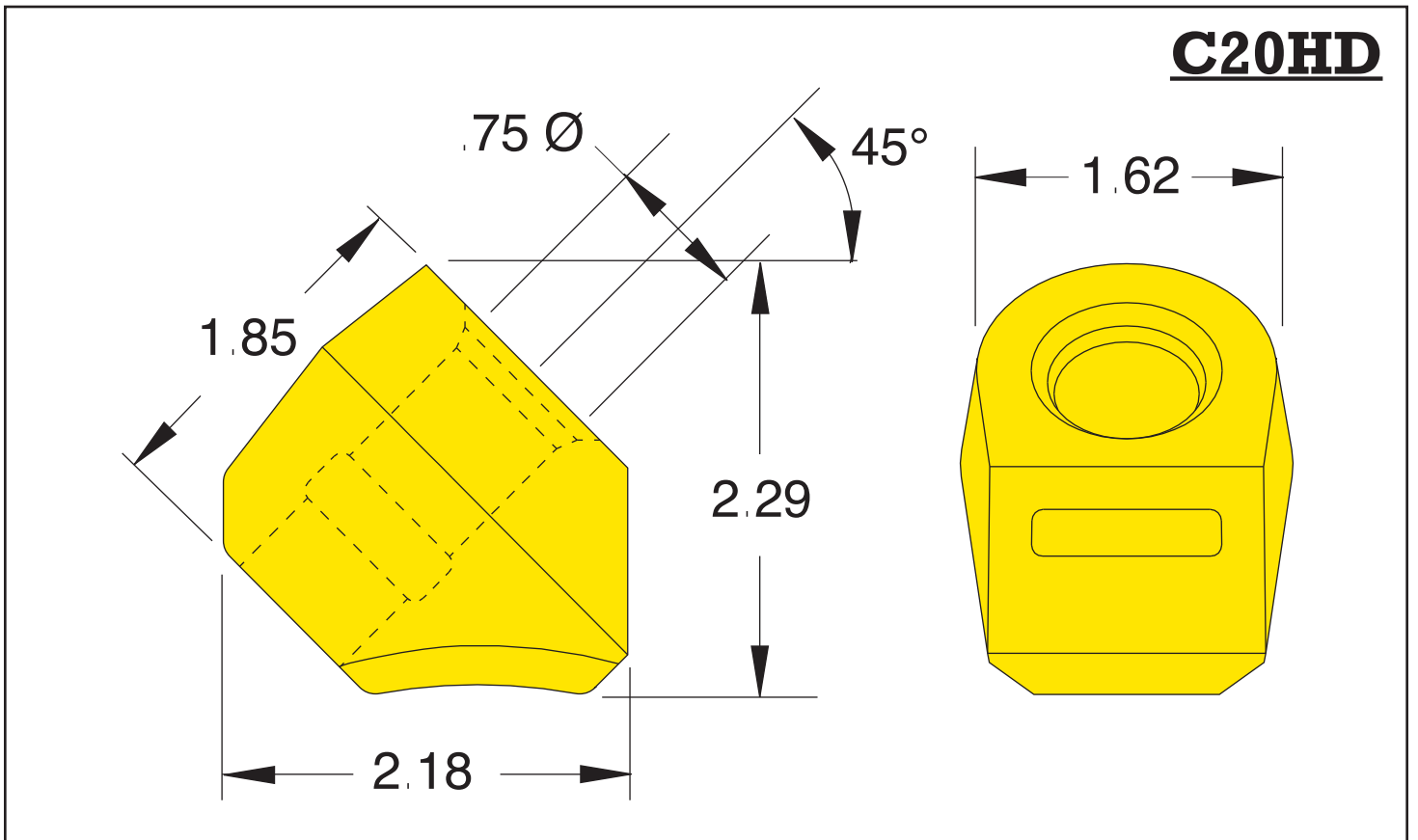
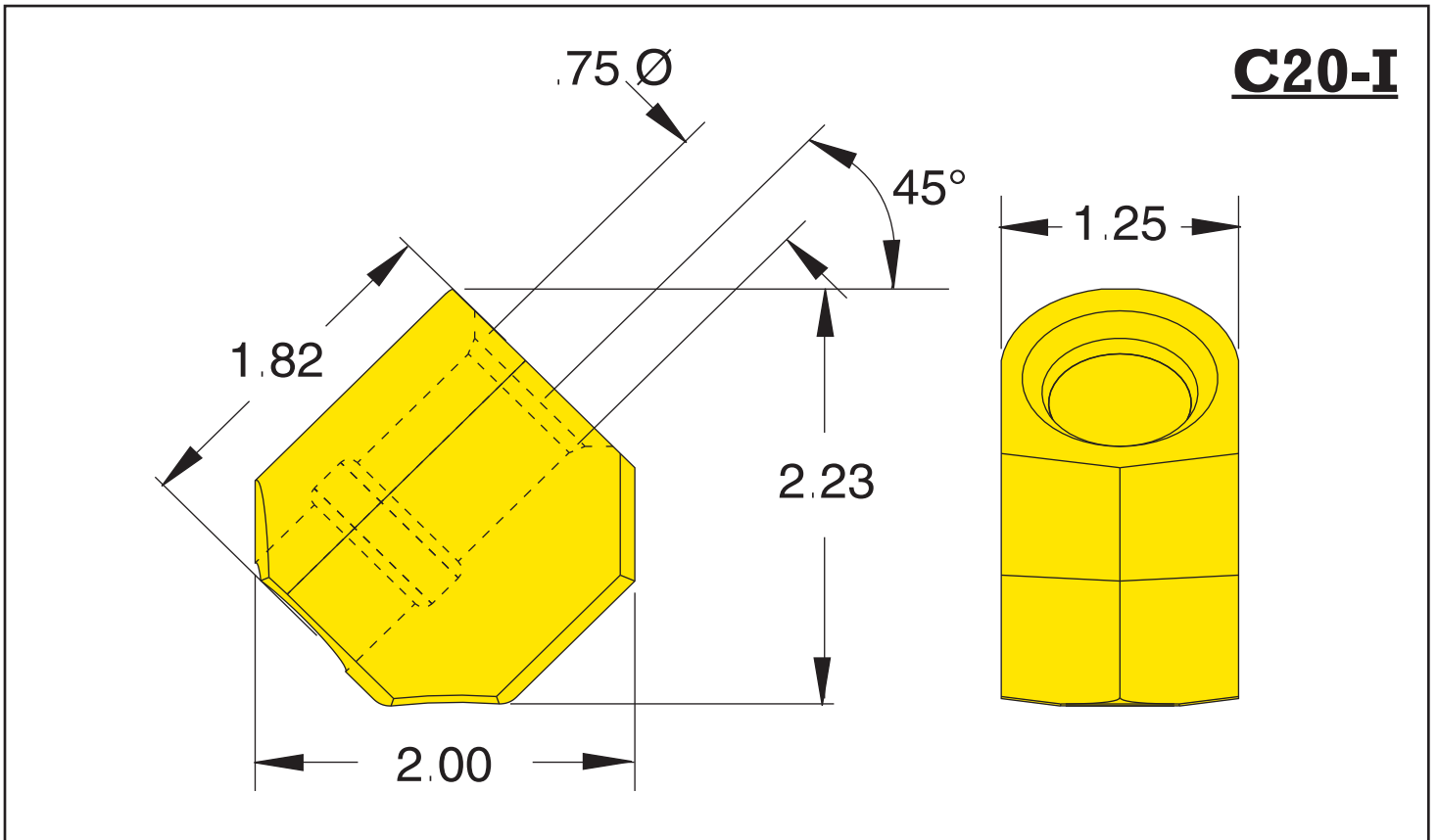

.76 Shank Series

Cutter Bits

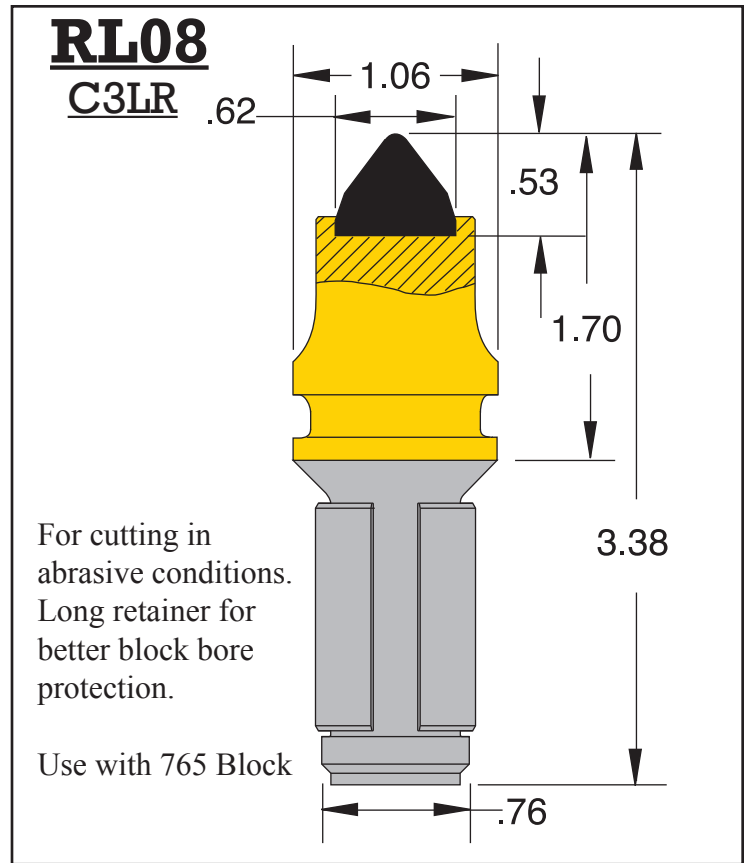
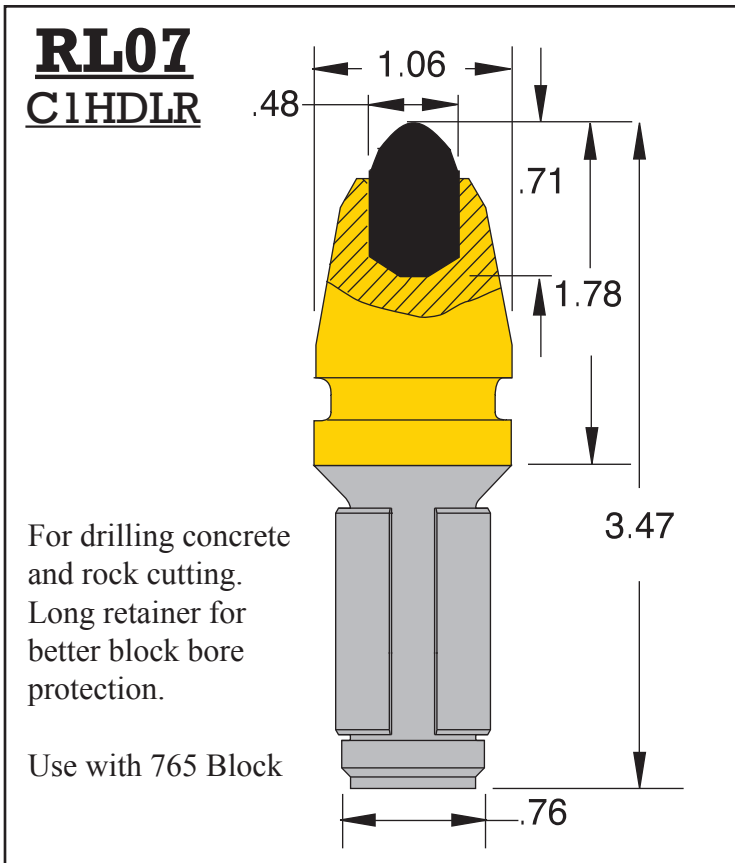
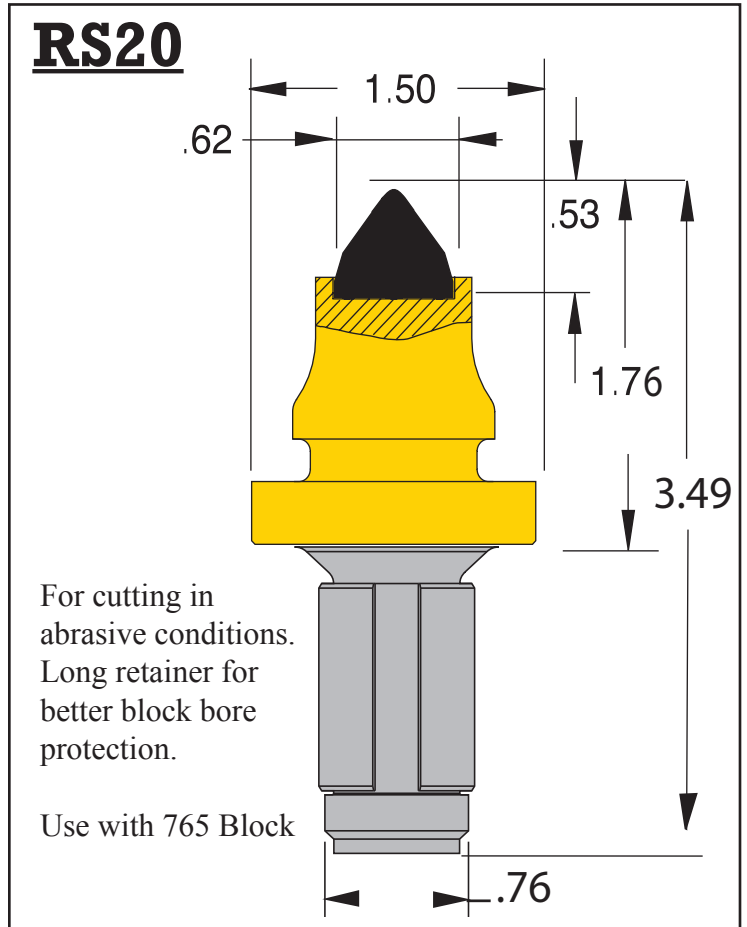
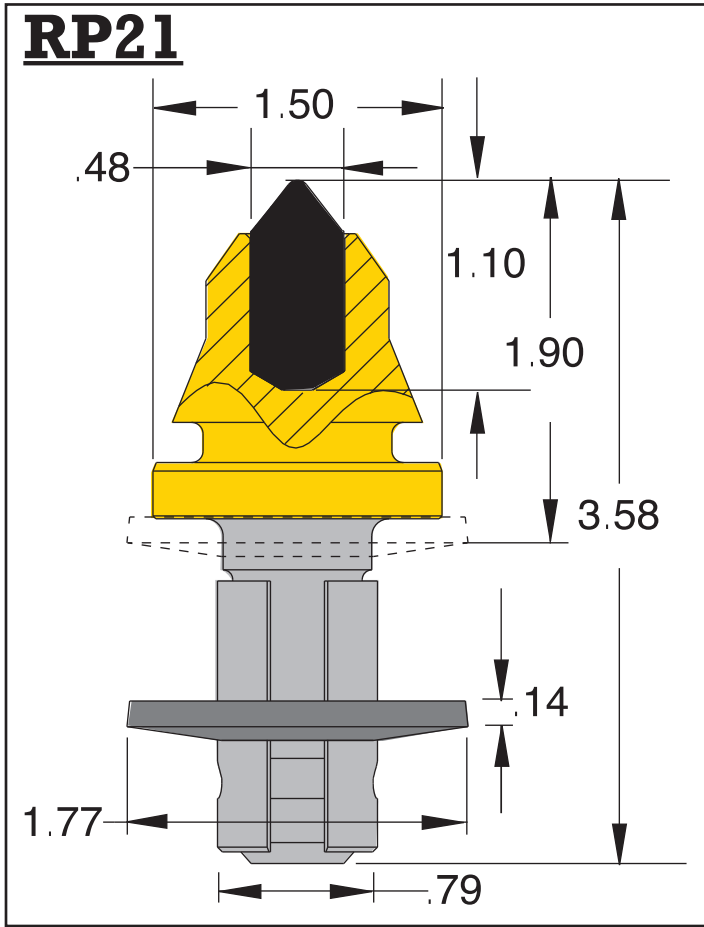

.76 Seires Blocks

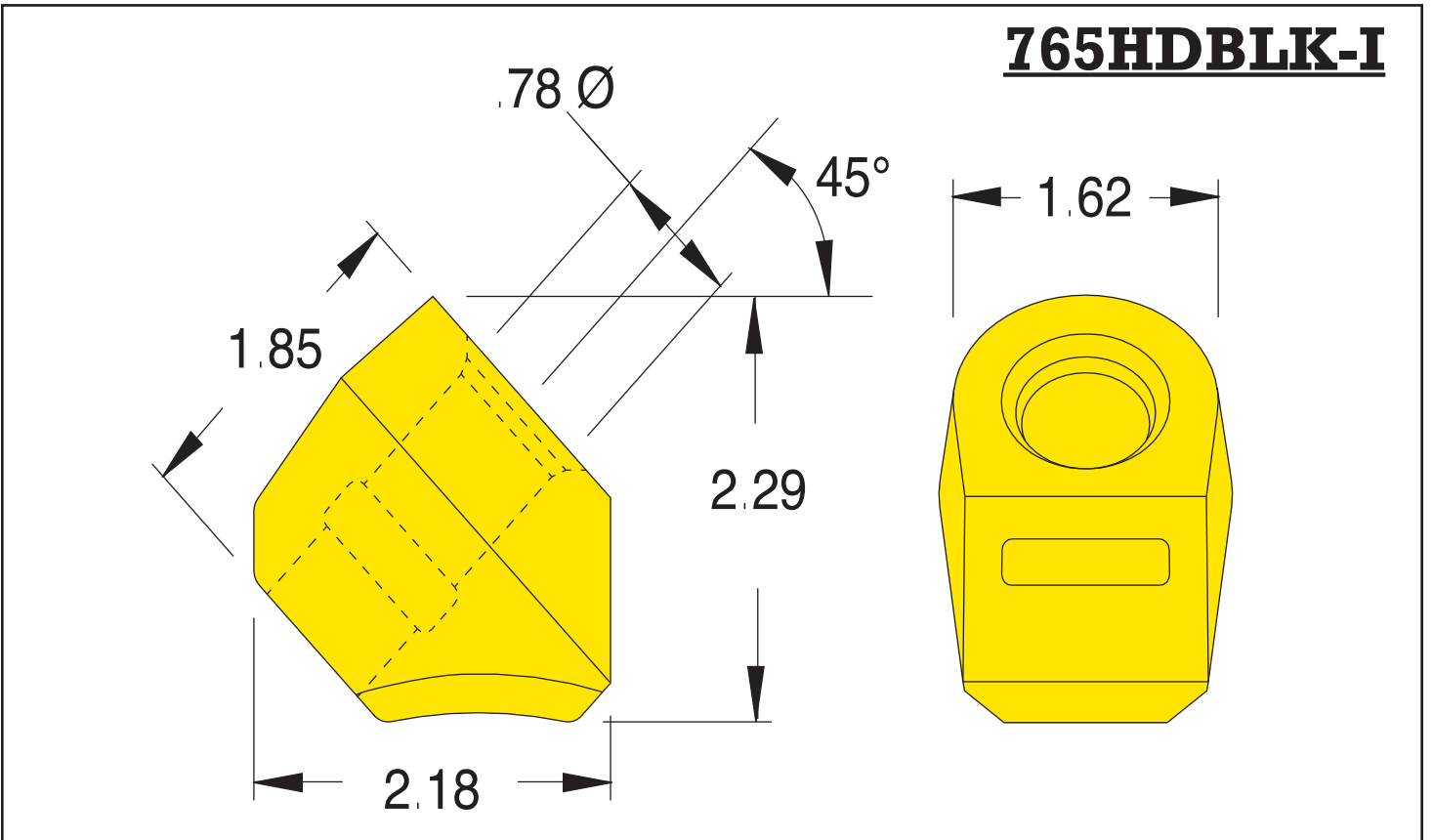
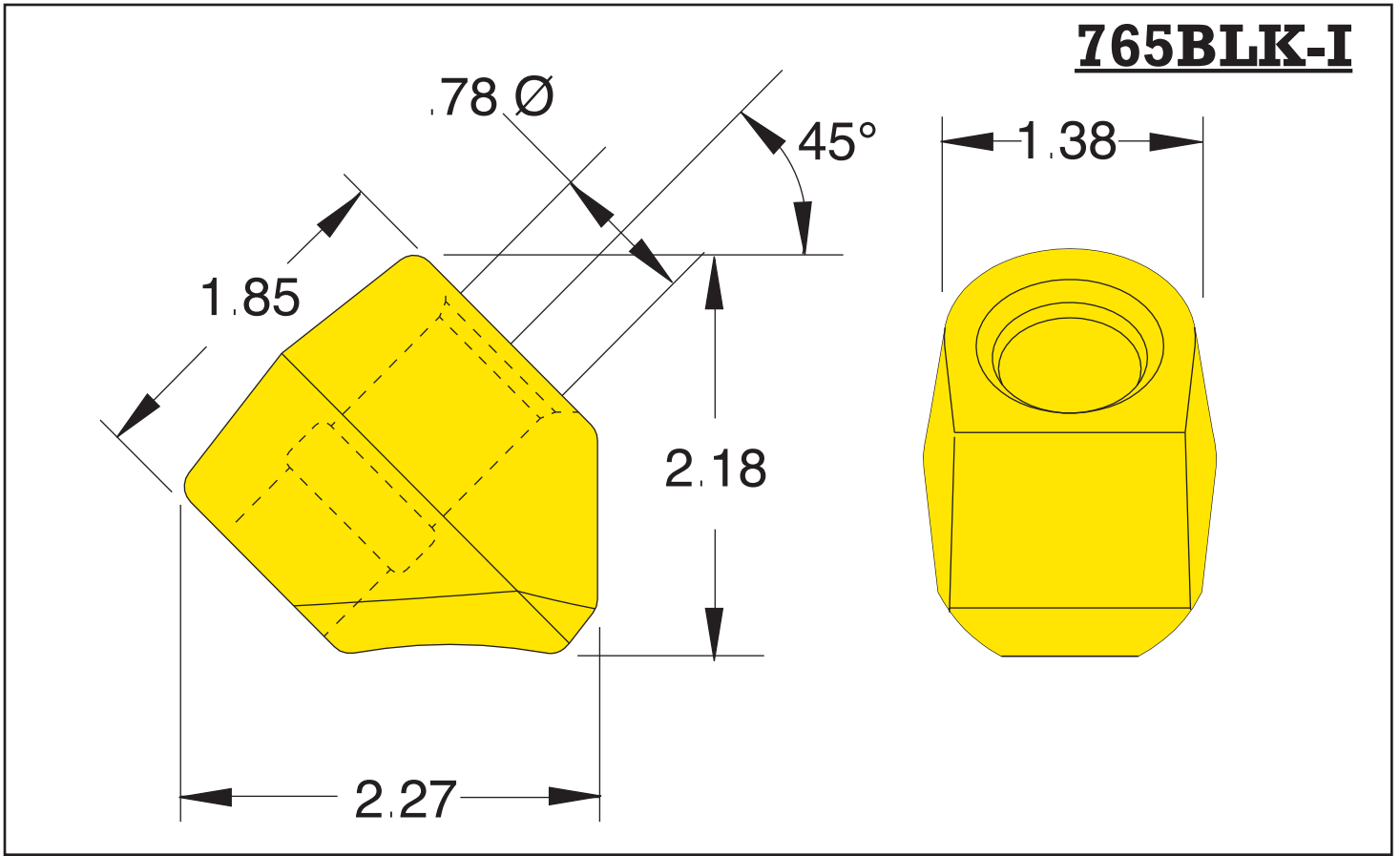

Cutter Bits

.86 Shank Series

S**M****O****2** **C****3****8****7****B****F**

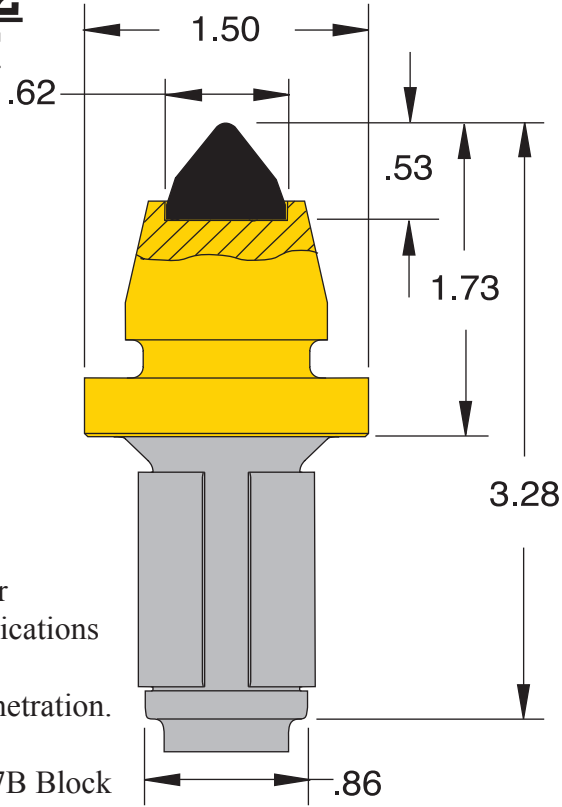

For asphalt or
abrasive applications
Sharp tip for
improved penetration.

Use with C87B Block

S**M****O****6** **C****8****7****B****F** .48

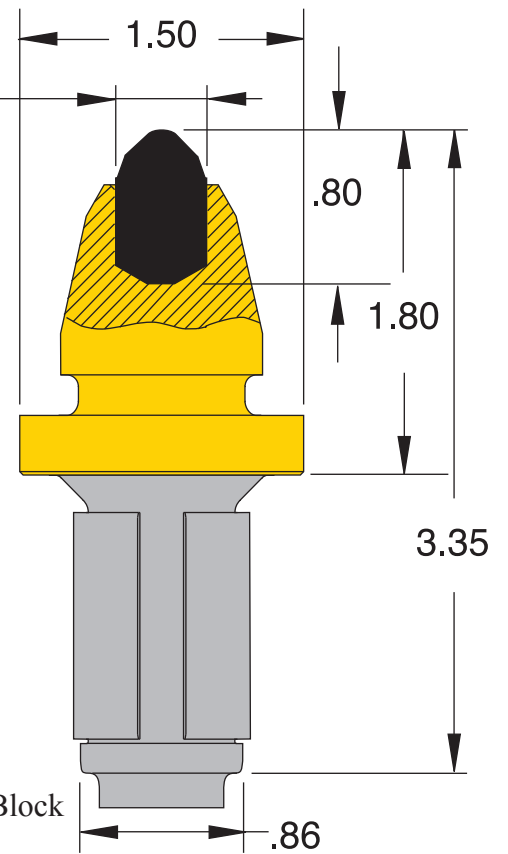

For drilling hard
rock or concrete.
Double-angle tip
for maximum
impact strength.

Use with C87B Block

S**L****O****2** **C****3****8****7****L****R**

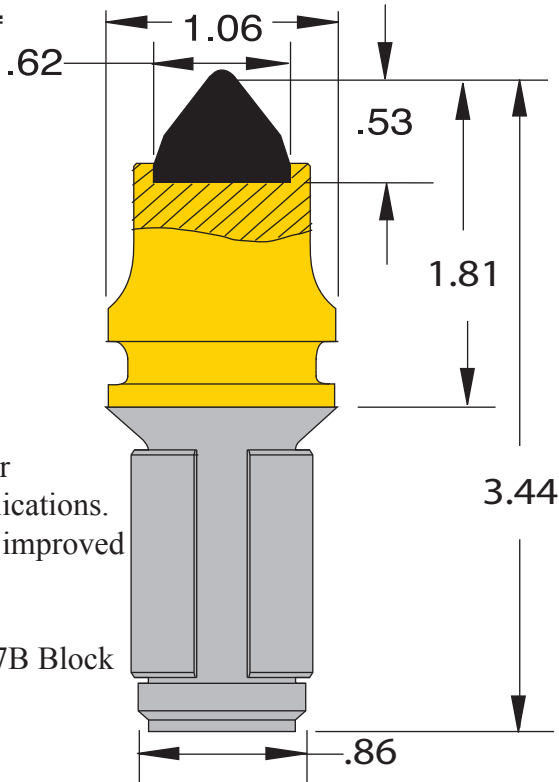

For asphalt or
abrasive applications.
Sharp tip for improved
penetration.

Use with C87B Block

S**L****O****4** **C****8****7****L****R**

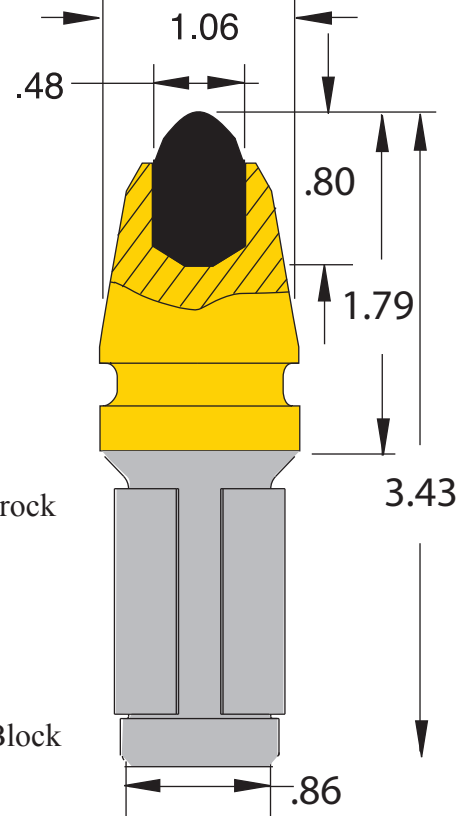

For drilling hard rock
or concrete.
Double-angle tip
for maximum
impact strength.

Use with C87B Block

Cutter Bits

AR150-87LR-I

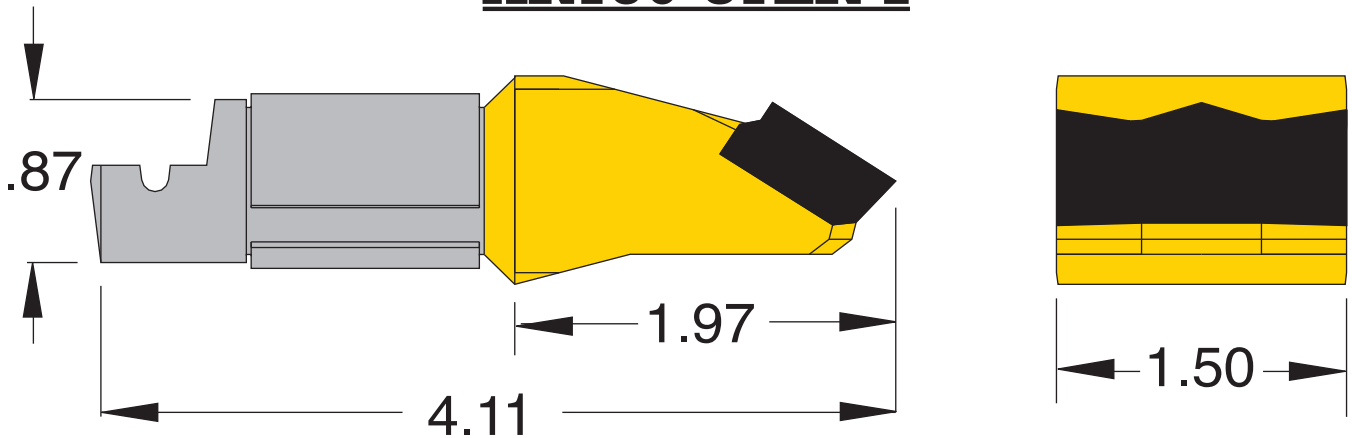

Spade, for soft to medium-hard
abrasive conditions.
Use with C87B Block

C858KCSB

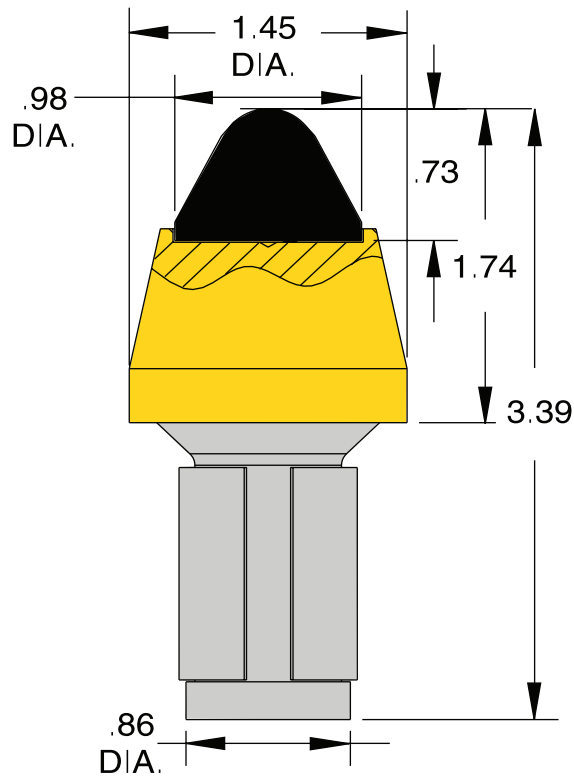

For use on all types of abrasive conditions.
Specially designed carbide tip for
extra-long tool life.
Use with C87B Block

.86 Series Blocks

C87B-I

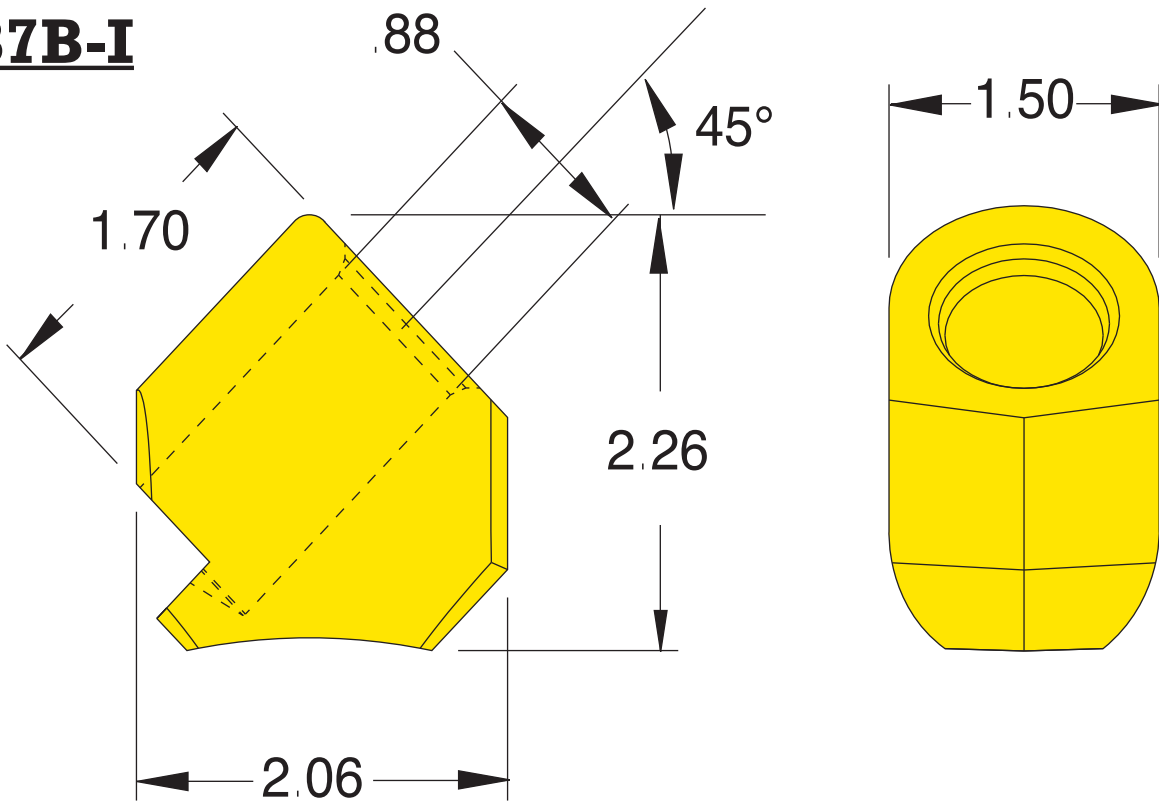

875HDBLK-I

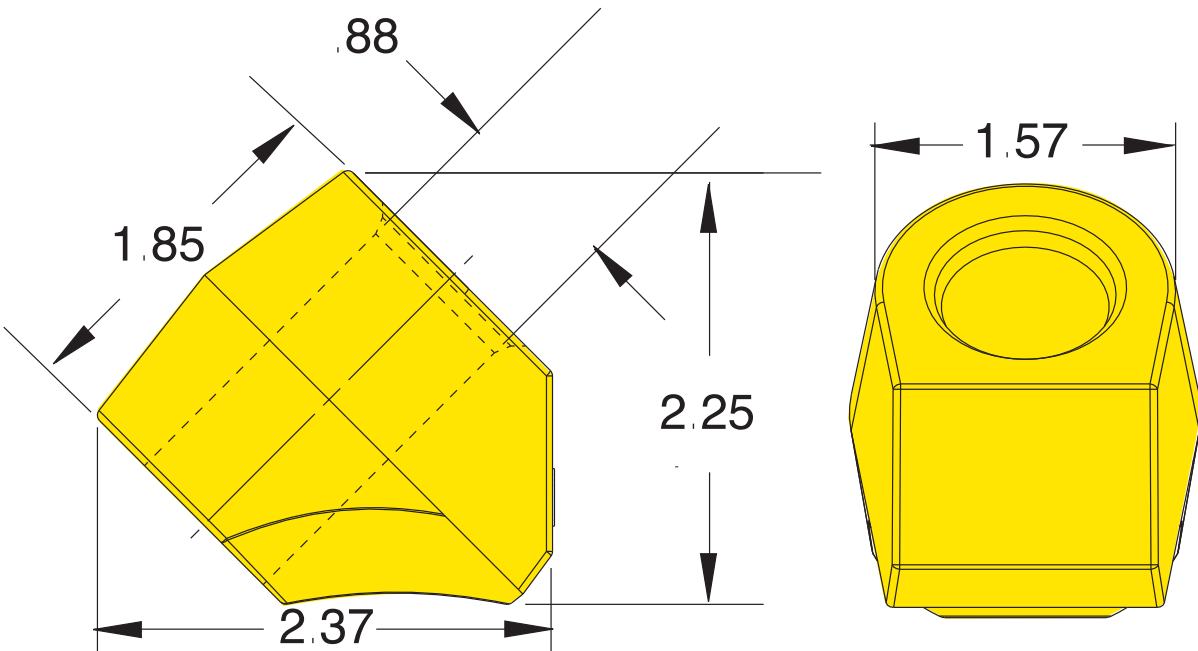

Cutter Bits

1.00 Shank Series

C31

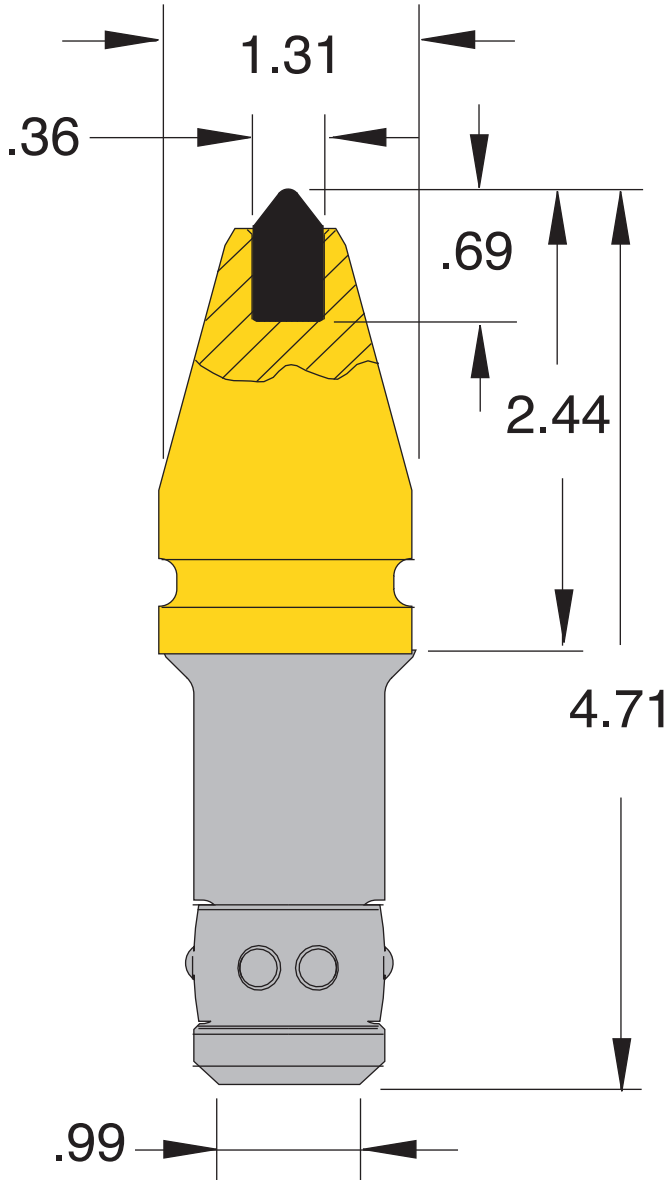

For drilling soft to hard rock and concrete.
Slender nose profile for increased penetration.
Use with C30 Block

C31HD

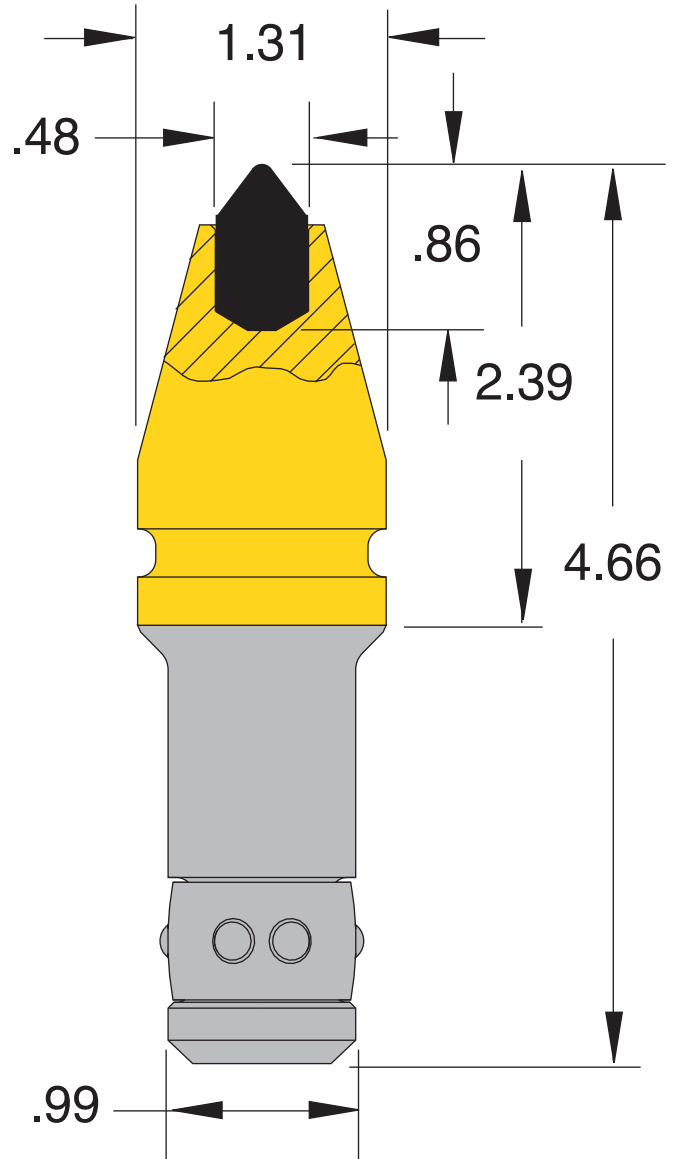

Heavy-duty design for drilling and tunnel boring in extremely hard rock and concrete.
Use with C30 Block

1.00 Shank Series

Cutter Bits

U40HD

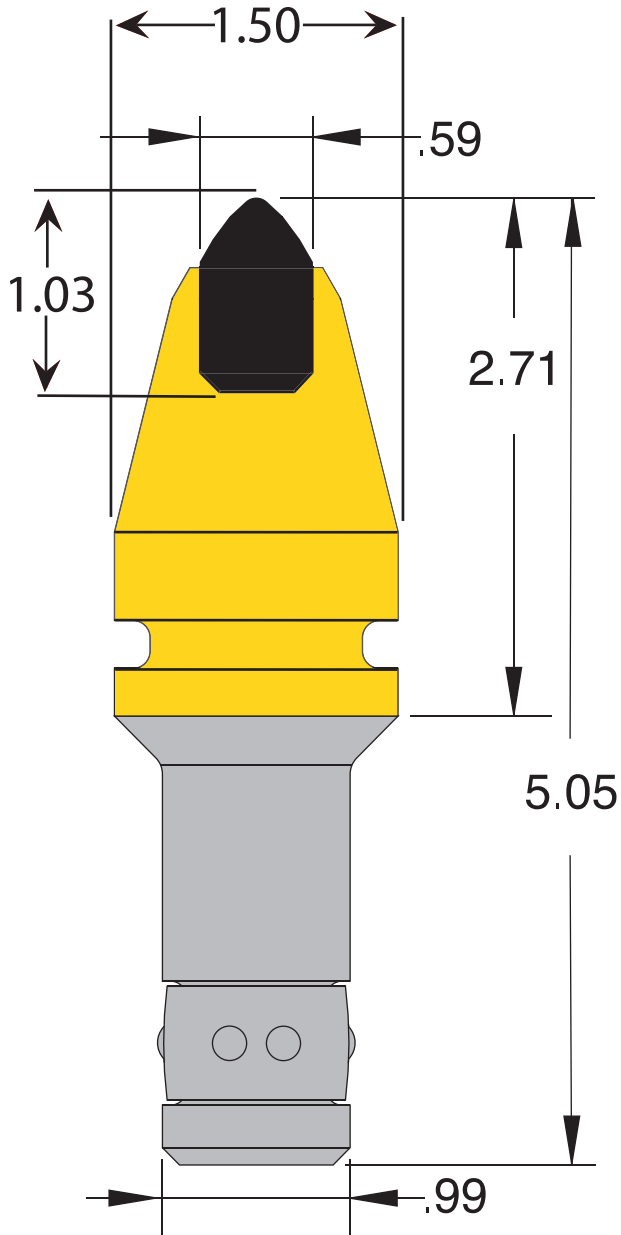

AUC40KH

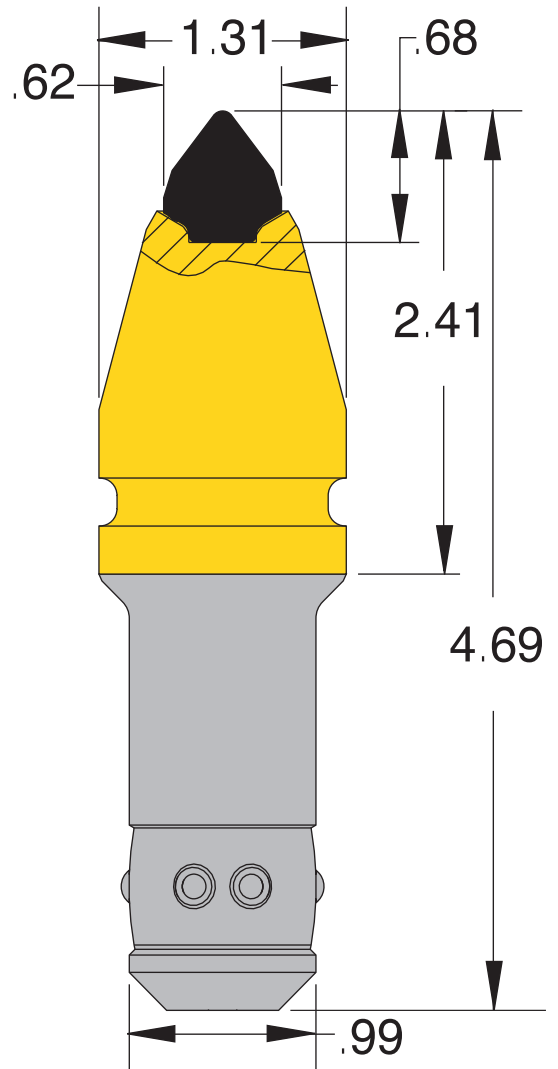

For augering and tunnel boring in extremely hard rock and concrete. Ballistic-style tip provides high impact strength
Use with C30 Block

For augering in soft to medium-hard cutting conditions where abrasive cutting washes away steel
Use with C30 Block

Cutter Bits

1.00 Series Series

CP65HBD

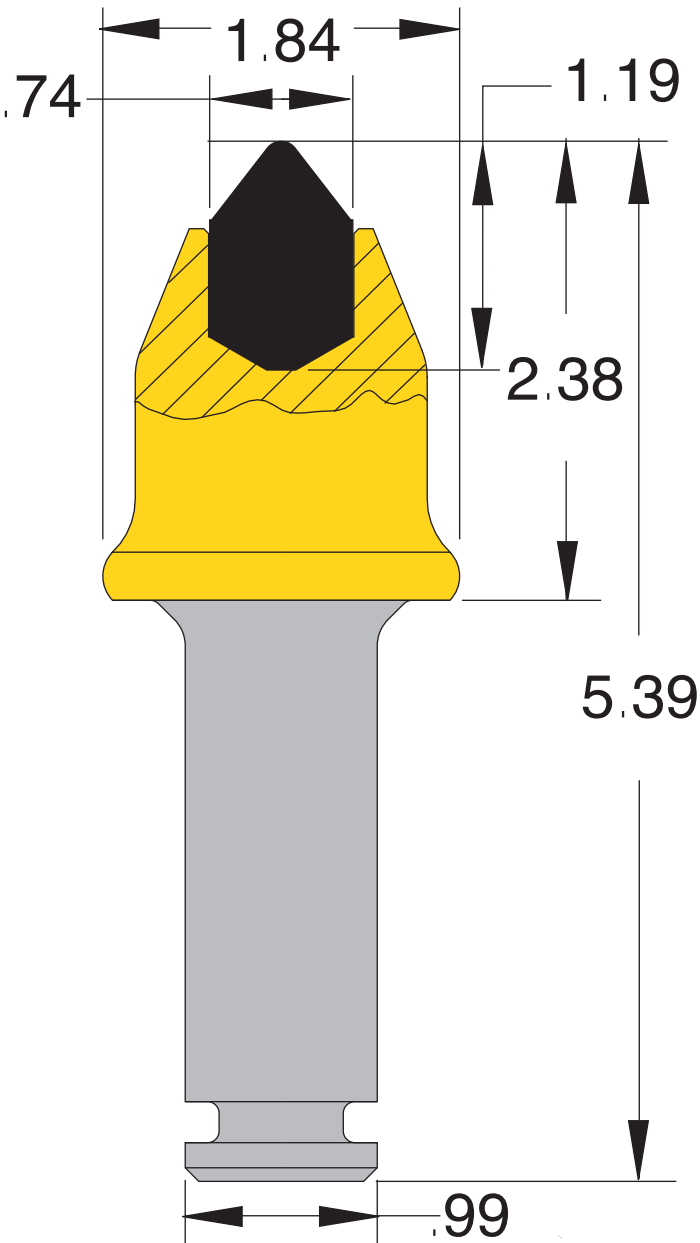

For drilling in hard and extremely abrasive rock.
Use with C30 Block

CP655

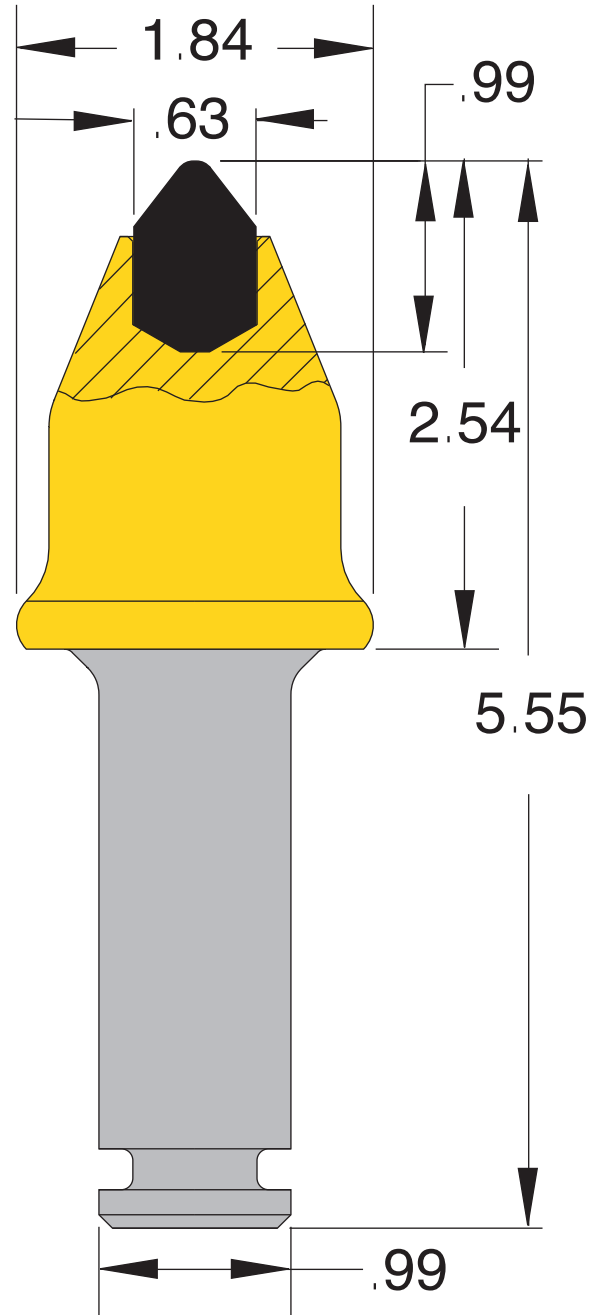

For drilling in medium to hard conditions.
Use with C30 Block

1.00 Series Blocks

C30-I

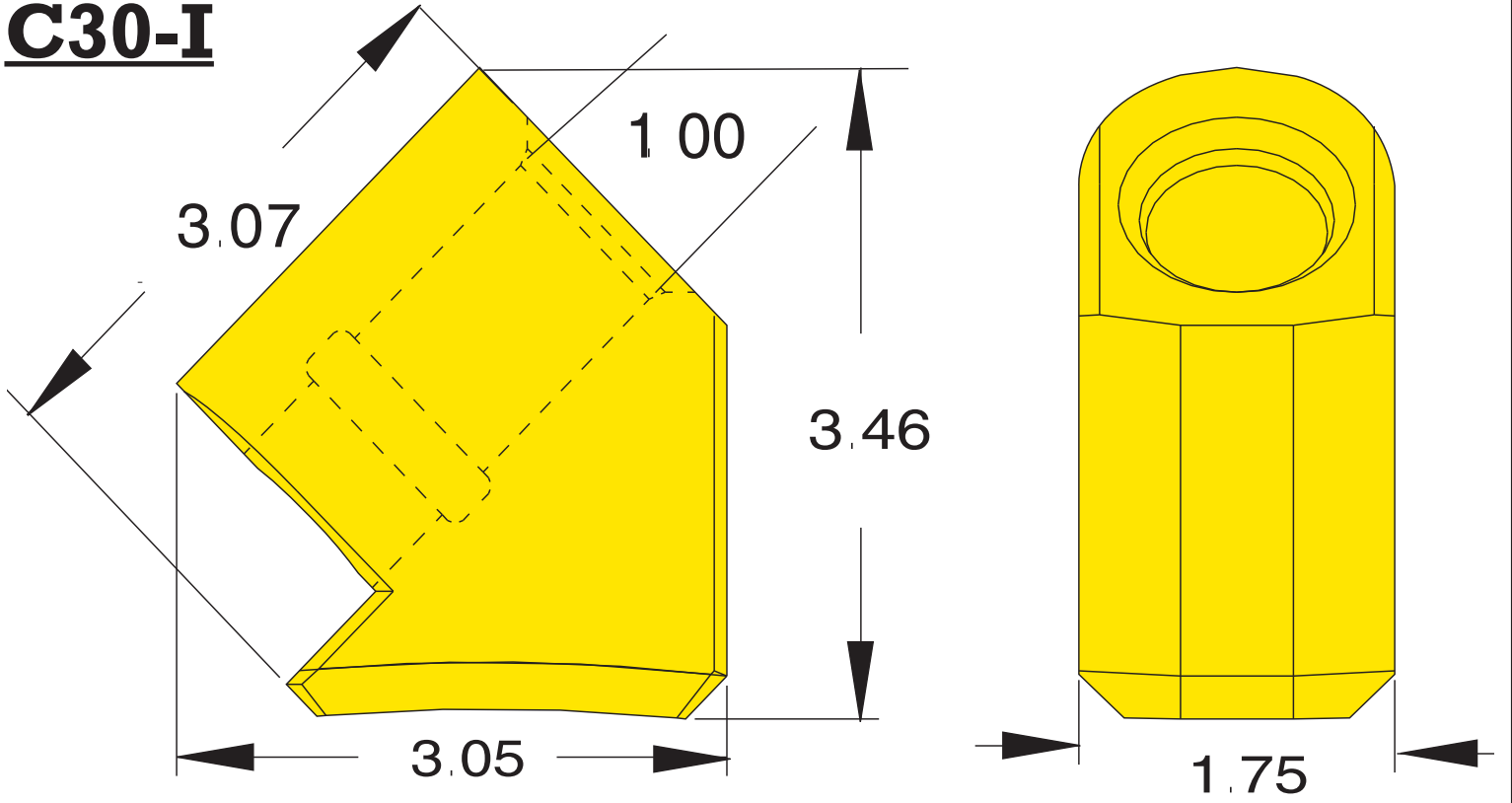

C30HD

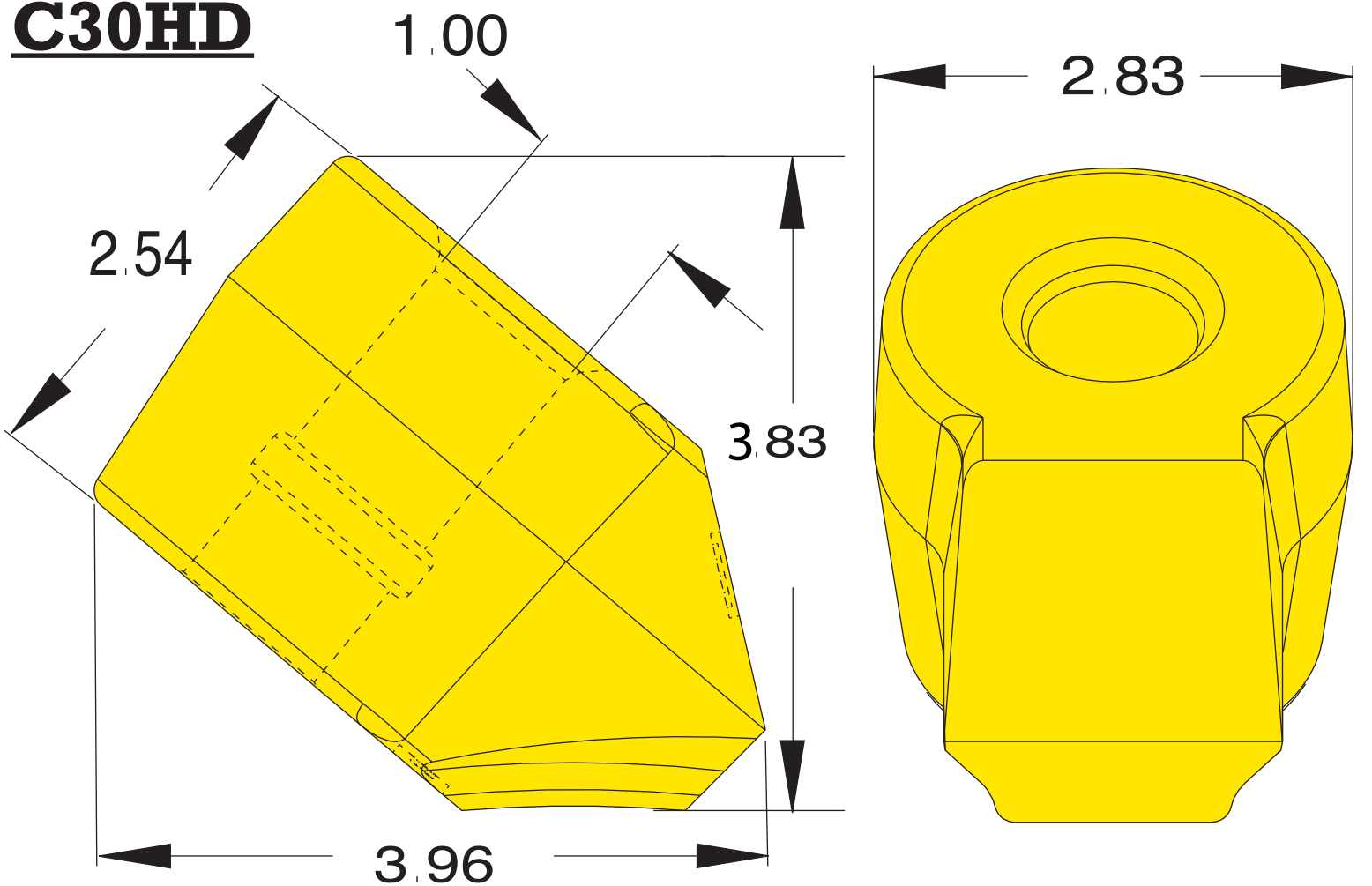

1.16 Shank Series

Cutter Teeth

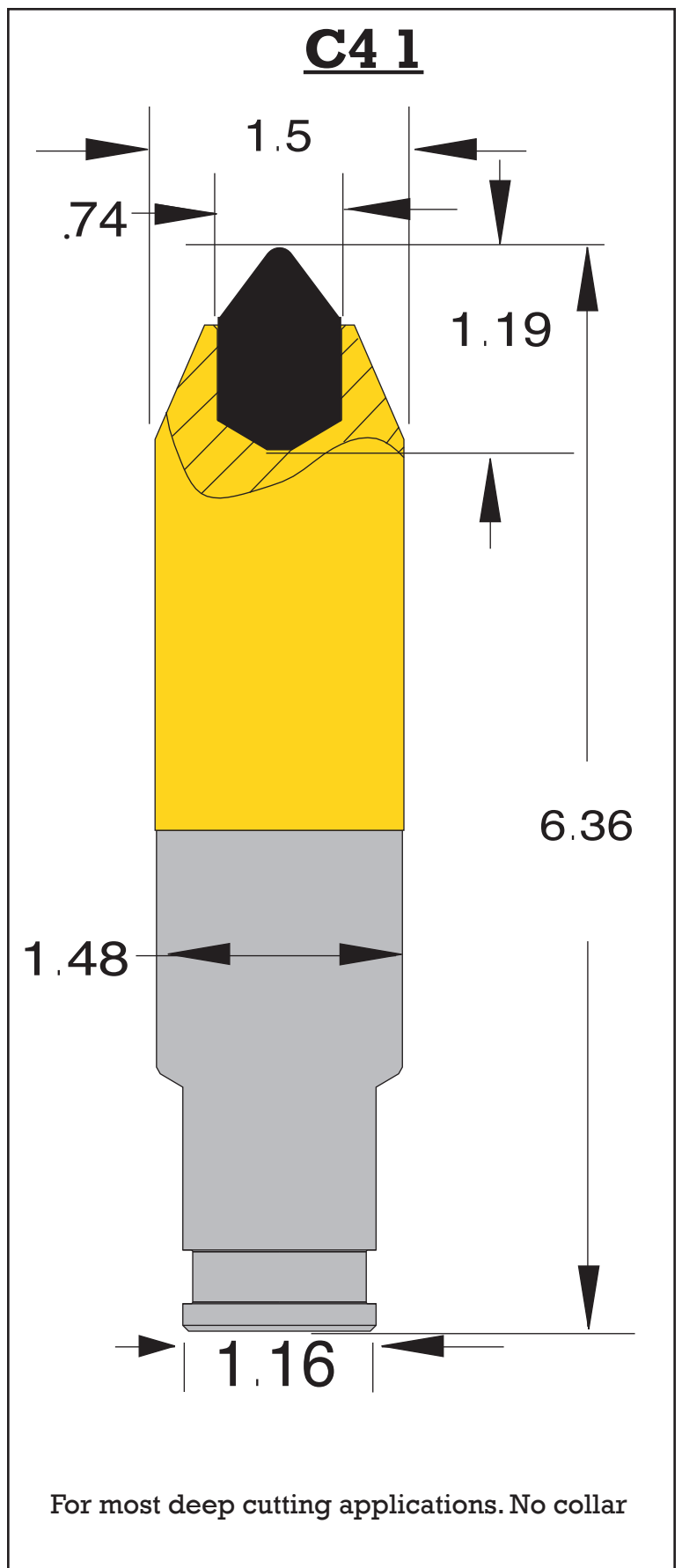
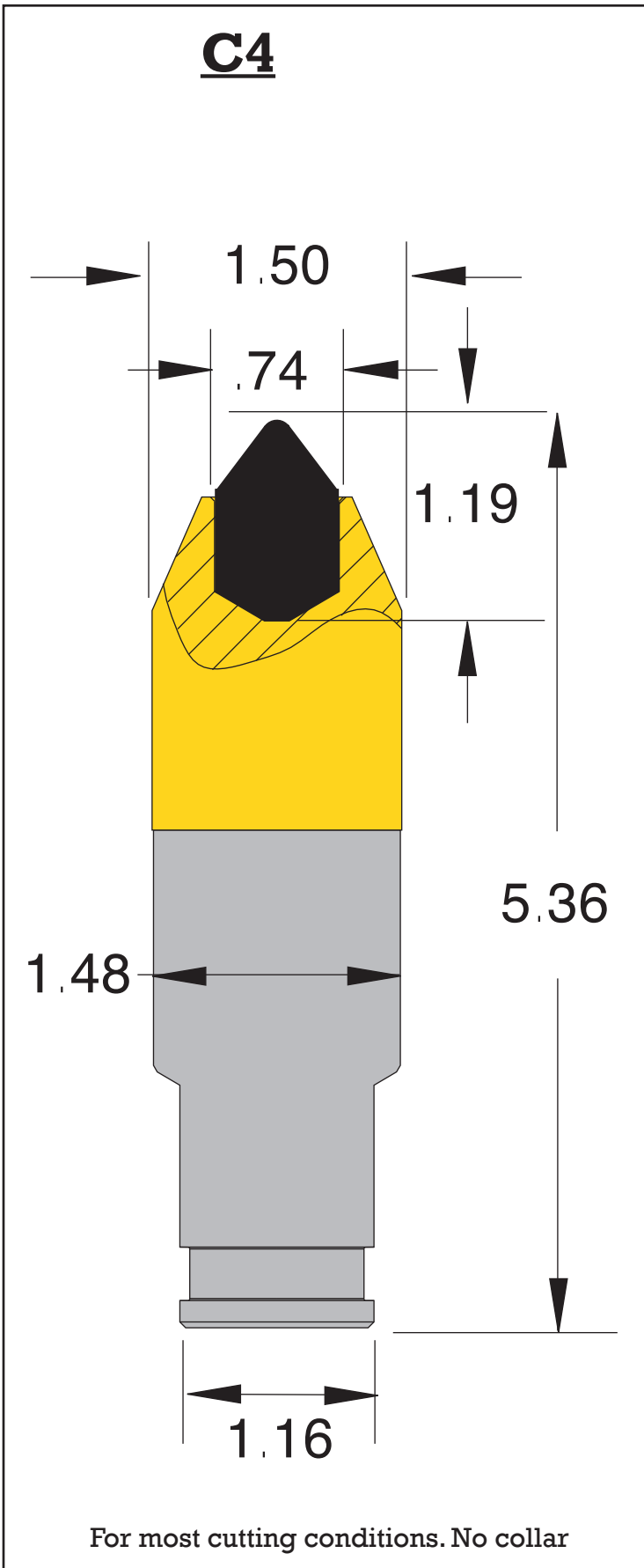

1.16 Shank Series

Cutter Teeth

DS01

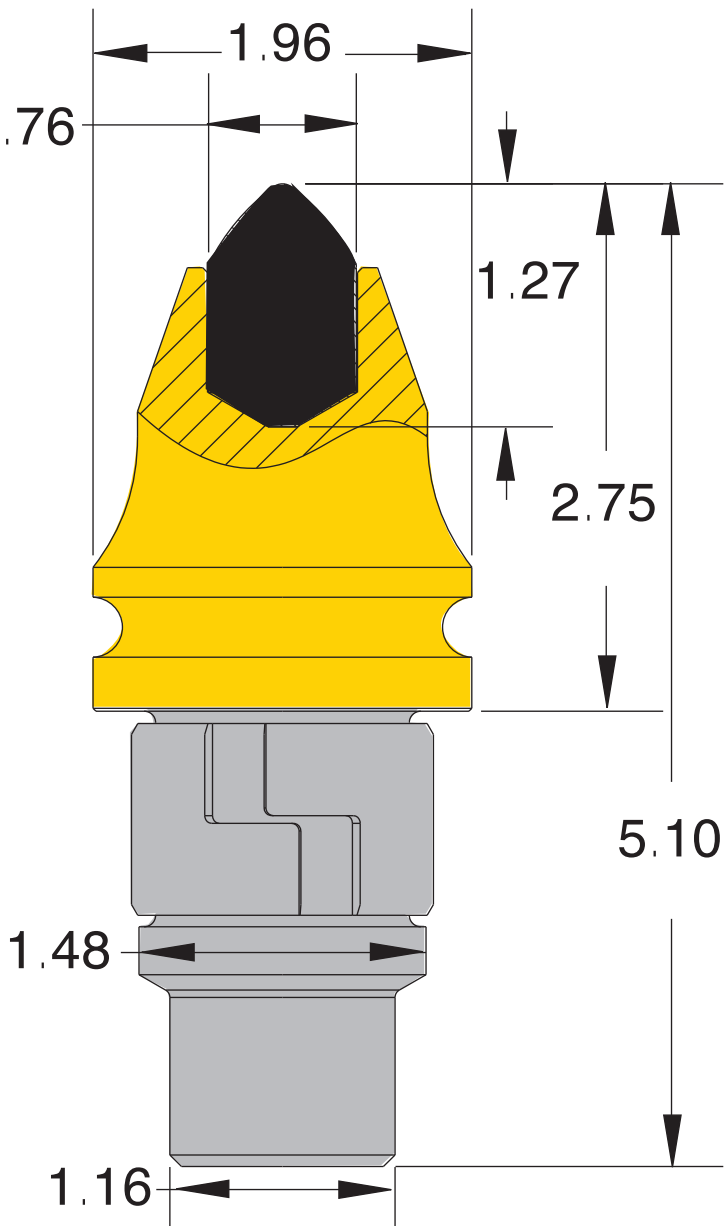

For drilling and tunnel boring in medium to extremely hard rock and concrete.

DS02

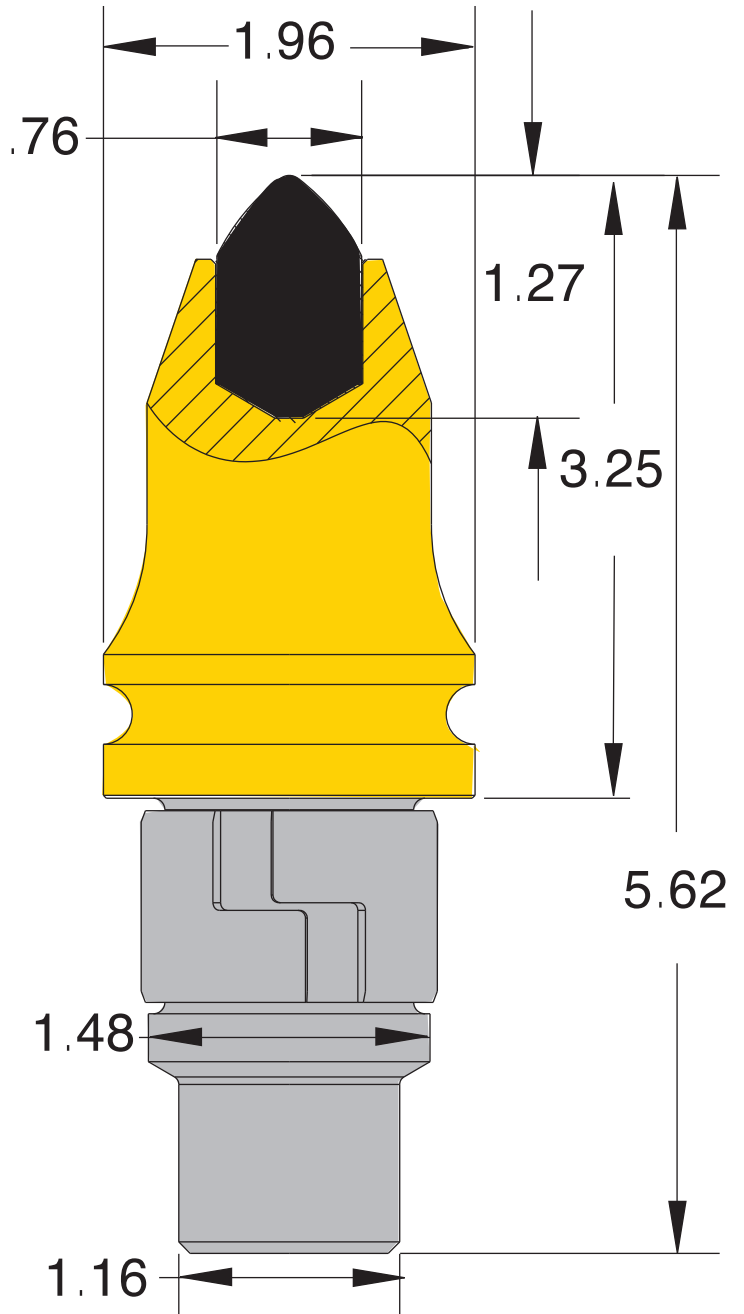

For drilling and tunnel boring in medium to extremely hard rock and concrete. Longer gage length for better penetration.

1.16 Series

Cutter Teeth

DS04

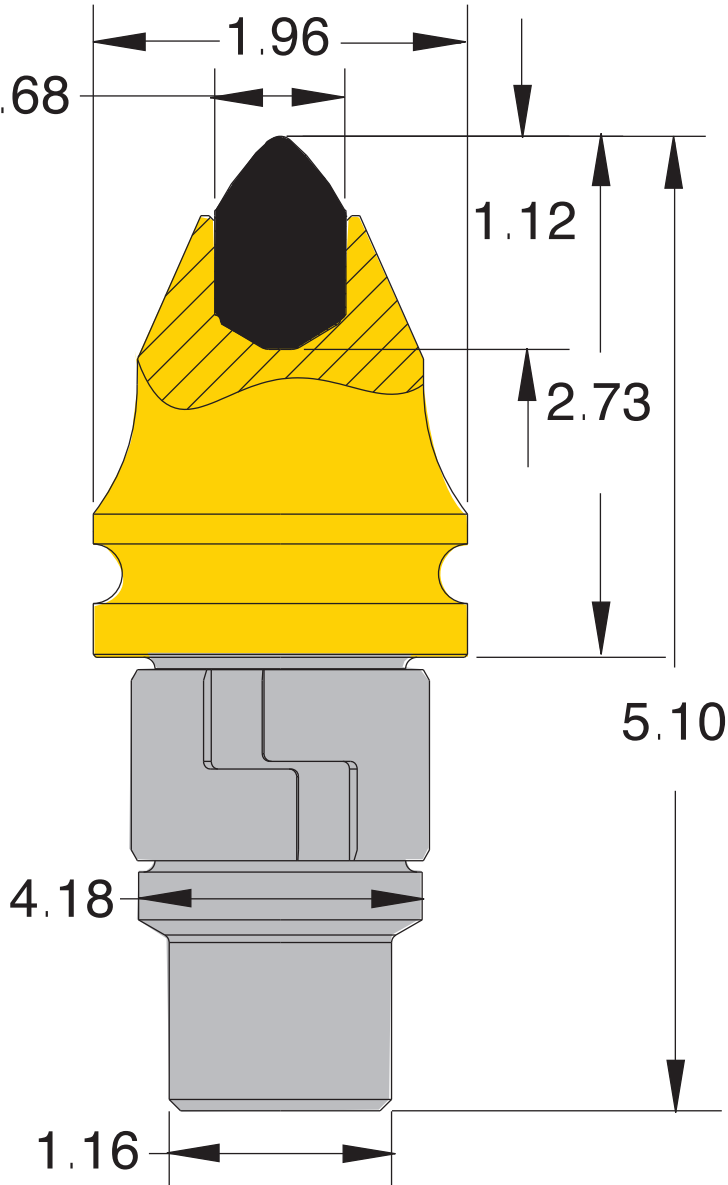

For drilling and tunnel boring in medium to hard rock.

DS05

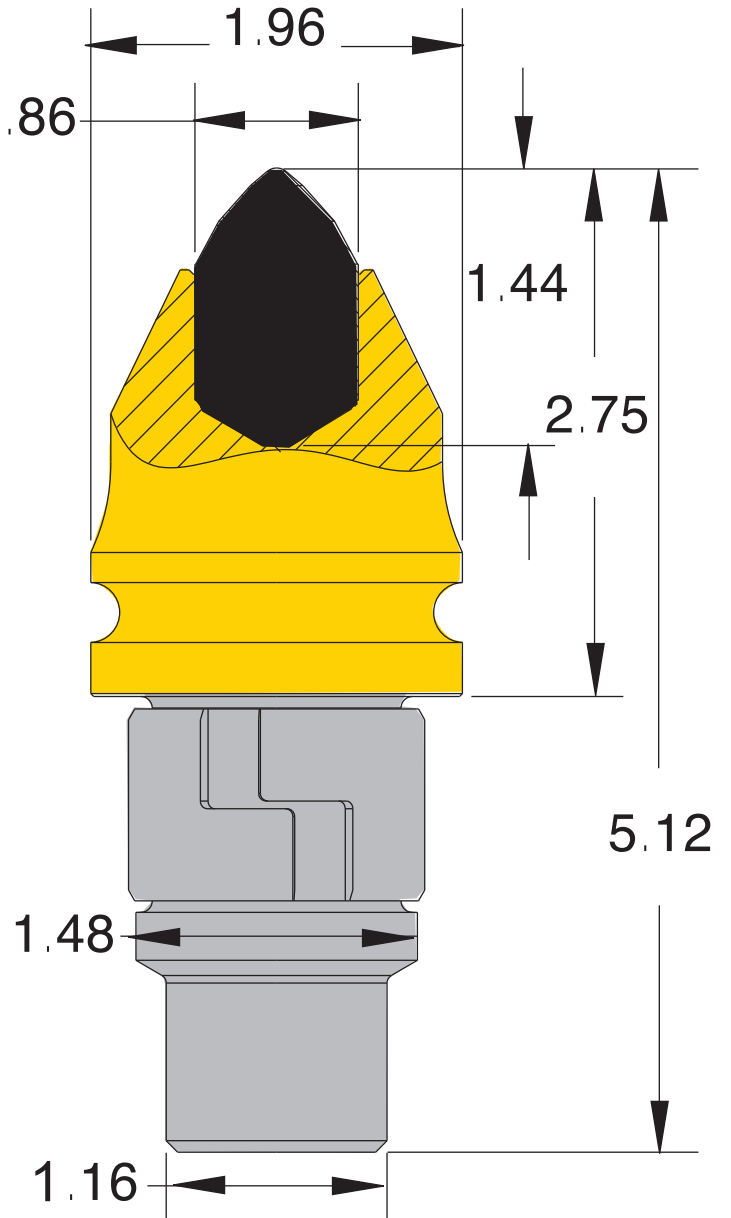

For drilling and tunnel boring in the most extreme hard rock and concrete.

1.16 Series Blocks

TH3-S

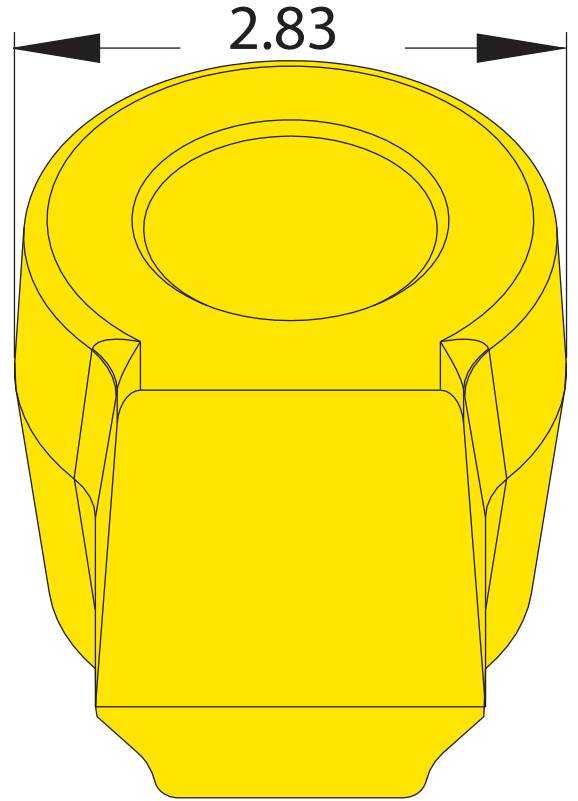
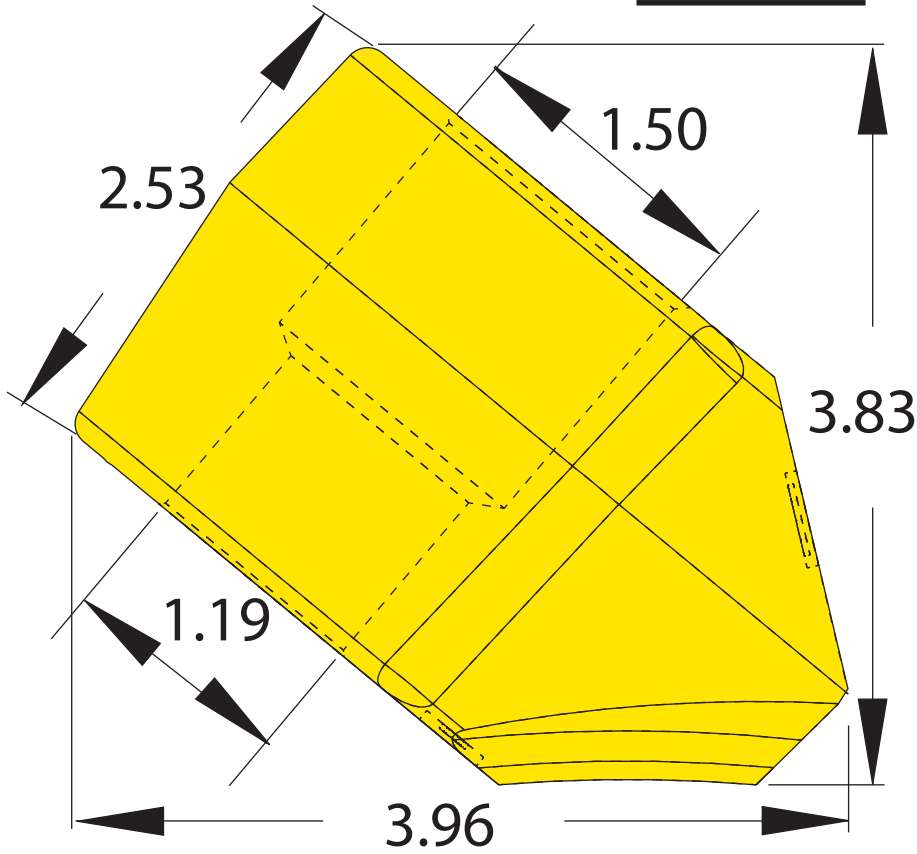

C4/U43H

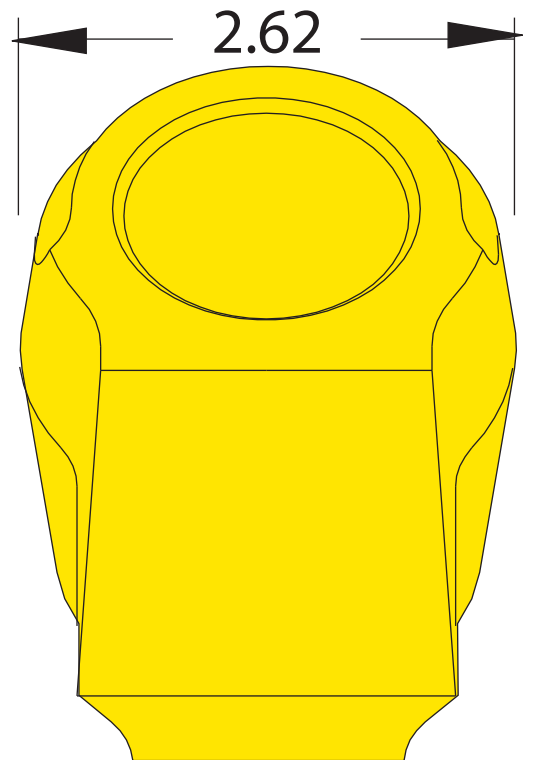
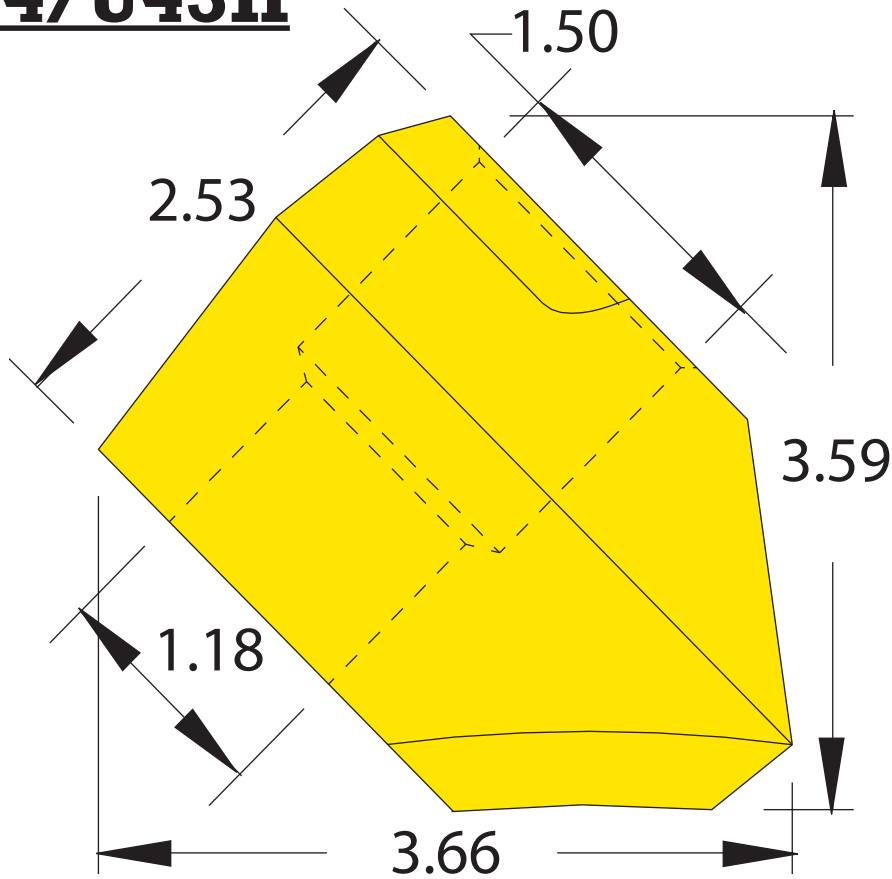

J Cutter Teeth

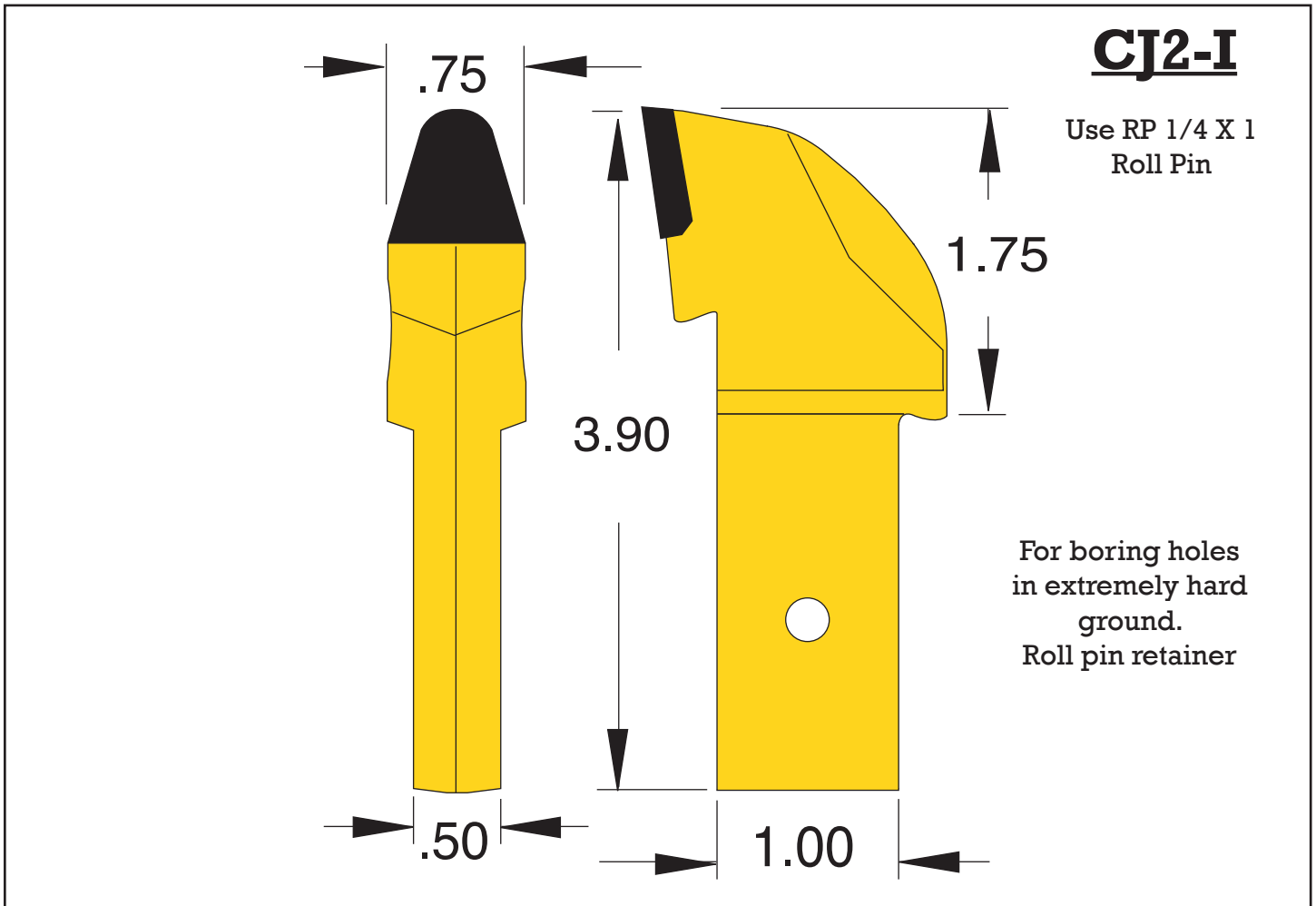

CJ2B-I BLOCK

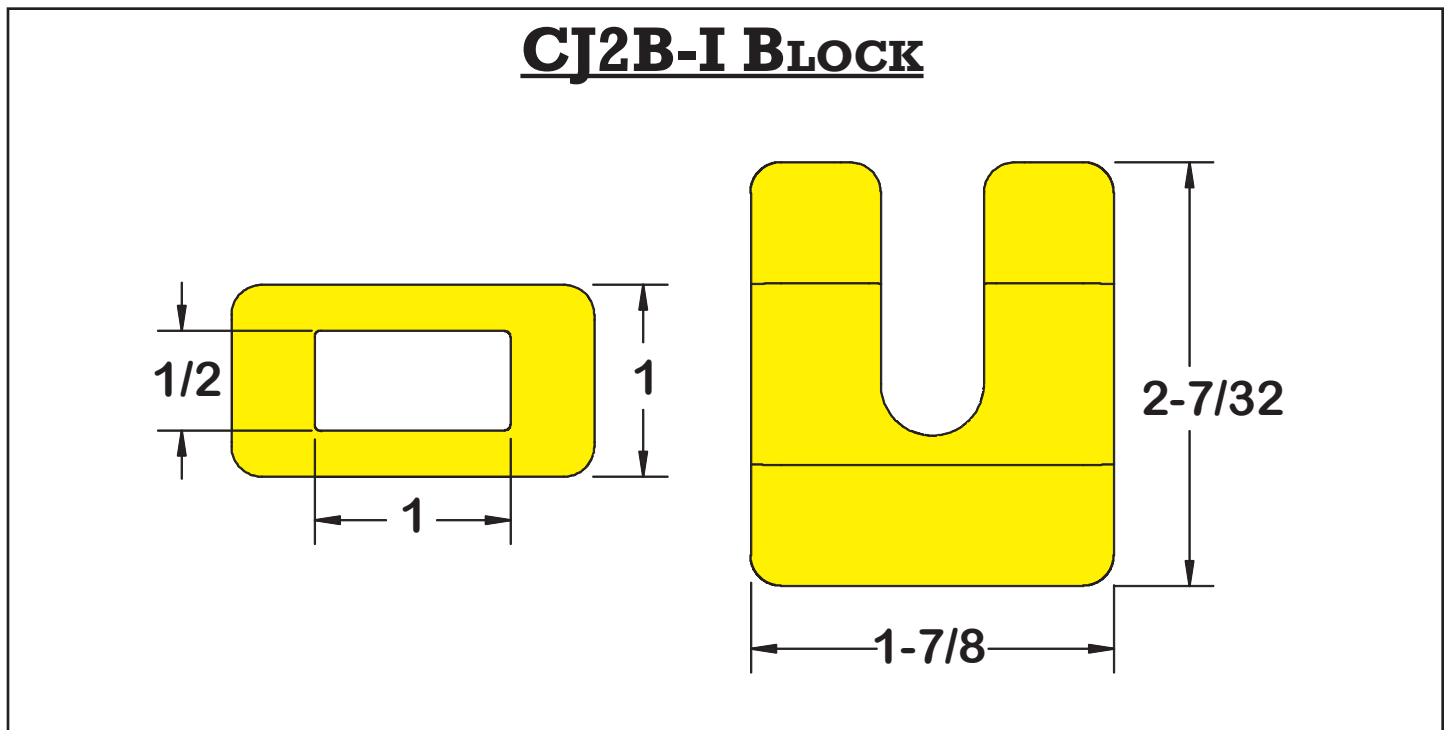

J Cutter Bits

U7-I

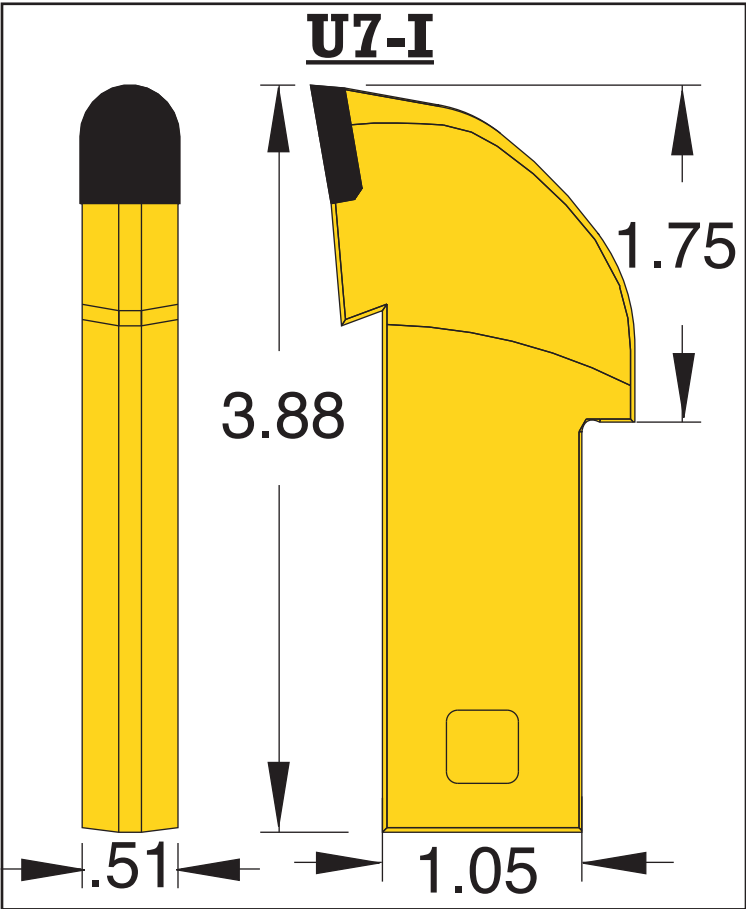

U7L-I

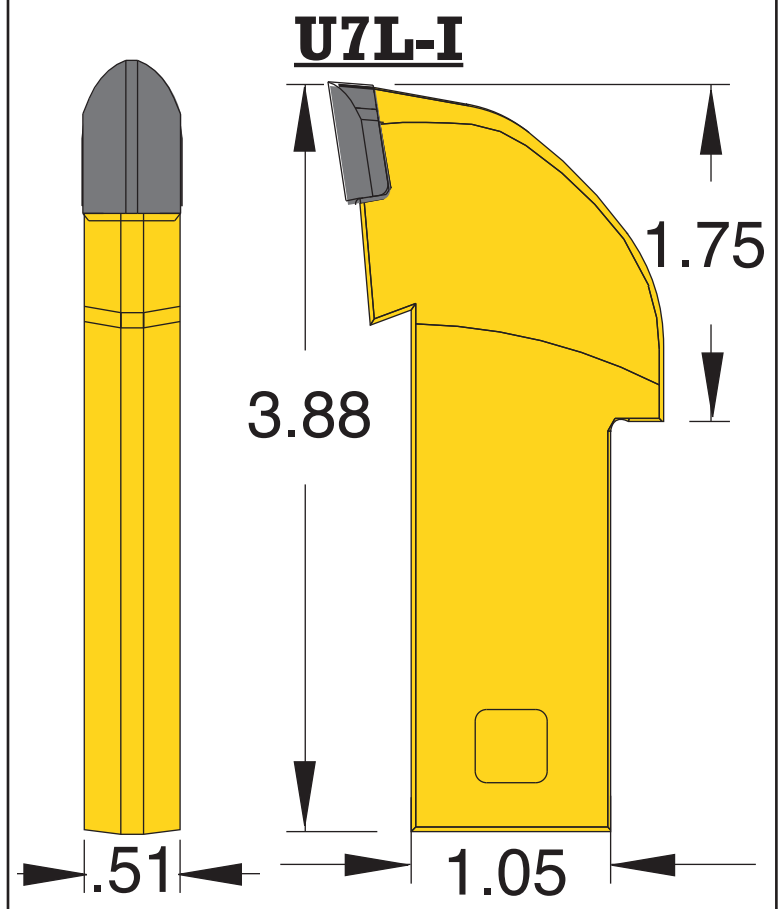

U7RAS

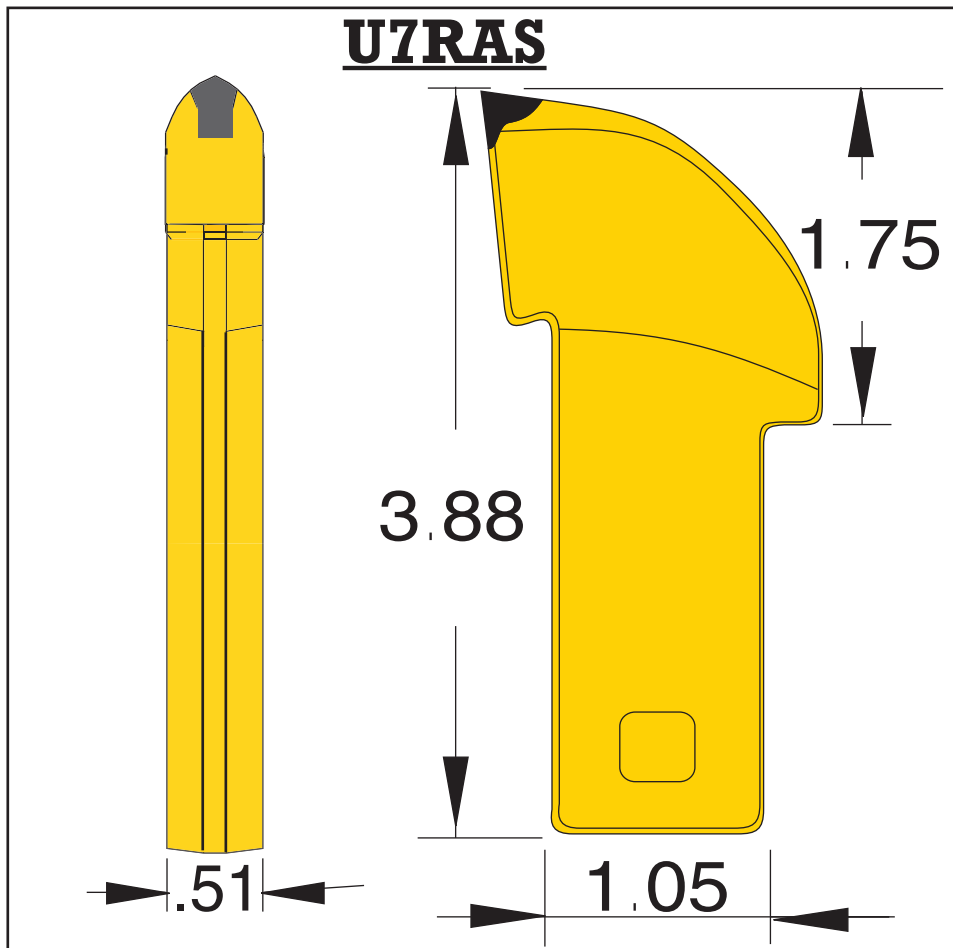

Cutter Bits

Tool	Type of Flange	Packaging		Container Weight		Pieces per pallet	Pallet Weight	
		Pieces per container	Containers per pallet	lbs.	kg.		lbs.	kg.
C31	small	25	50	27.53	12.52	1250	1426	648
C31HD	small	25	50	27.70	12.59	1250	1435	652
CP655	medium	15	50	26.03	11.85	750	1353	615
CP65HBD	medium	15	50	26.06	11.85	750	1353	615
C4		15	50	32.63	14.83	750	1681	764
C4 1		15	50	39.72	18.06	750	2036	925
AUC40KH	Small	25	50	27.31	12.42	1250	1415	643
U40HD	Small	25	50	35.19	15.99	1250	1809	822
DS01	Large	12	50	35.50	16.14	750	1825	829
DS02	Large	12	50	39.17	17.81	600	2008	913
DS04	Large	15	50	34.61	15.73	750	1780	809
DS05	Large	12	50	30.51	13.87	600	1575	716
CJ2-I	J Bit	50	50	33.75	15.34	2500	1737	789
U7-I	J Bit	50	50	29.35	13.34	2500	1517	689
U7L-I	J Bit	50	50	29.57	13.44	2500	1528	694
URAS-I	J Bit	50	50	29.35	13.34	2500	1517	689

Blocks

Tool	Old Tool Name	Packaging		Container Weight		Pieces per pallet	Pallet Weight	
		Pieces per container	Containers per pallet	lbs.	kg.		lbs.	kg.
CMB4	CMMB2	200	50	19.29	42.44	10000	2175.06	987.30
CMB6	CMMB6	200	50	16.89	37.16	10000	1908.06	867.30
C20-I		40	50	29.41	13.37	2000	1520.86	691.30
C20HD		25	50	30.50	13.87	1250	1575.31	716.50
765BLK-I		35	50	33.19	15.09	1750	1709.51	777.05
765HDBLK-I		25	50	30.89	14.04	1250	1594.56	724.80
C87B		25	50	22.81	10.37	1250	1190.31	541.05
875HDBLK	C87HDS	25	50	31.71	14.42	1250	1635.81	743.55
C30		12	50	30.22	13.74	750	1820.06	827.30
C30HD		6	50	29.58	13.44	300	1529.00	695.00
C4/U43H		8	50	29.41	13.37	400	1520.86	691.30
TH3-S		6	50	26.82	12.19	300	1391.06	632.30
CJ2B-I		30	50	21.54	9.79	1500	1127.06	512.30

Cutting Tools Accessories

Hammer-type Pullers for removal of tools

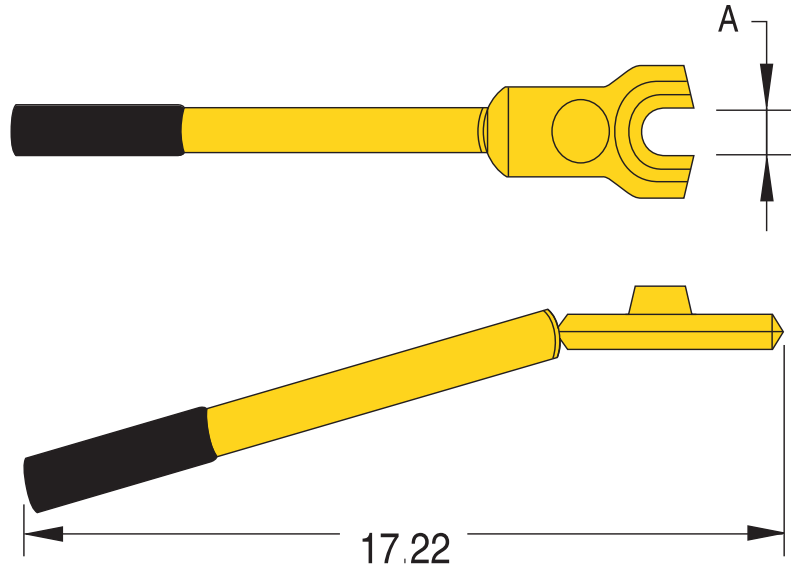

Description	For	Dimmensions
		A
C20 HP puller	C20 tools	.84
C30 HP puller	C30 tools	1.15
C123 puller	.76 & .86 Shanks	.91

Snap Ring Pliers



KRP-4

